

# VeGESack

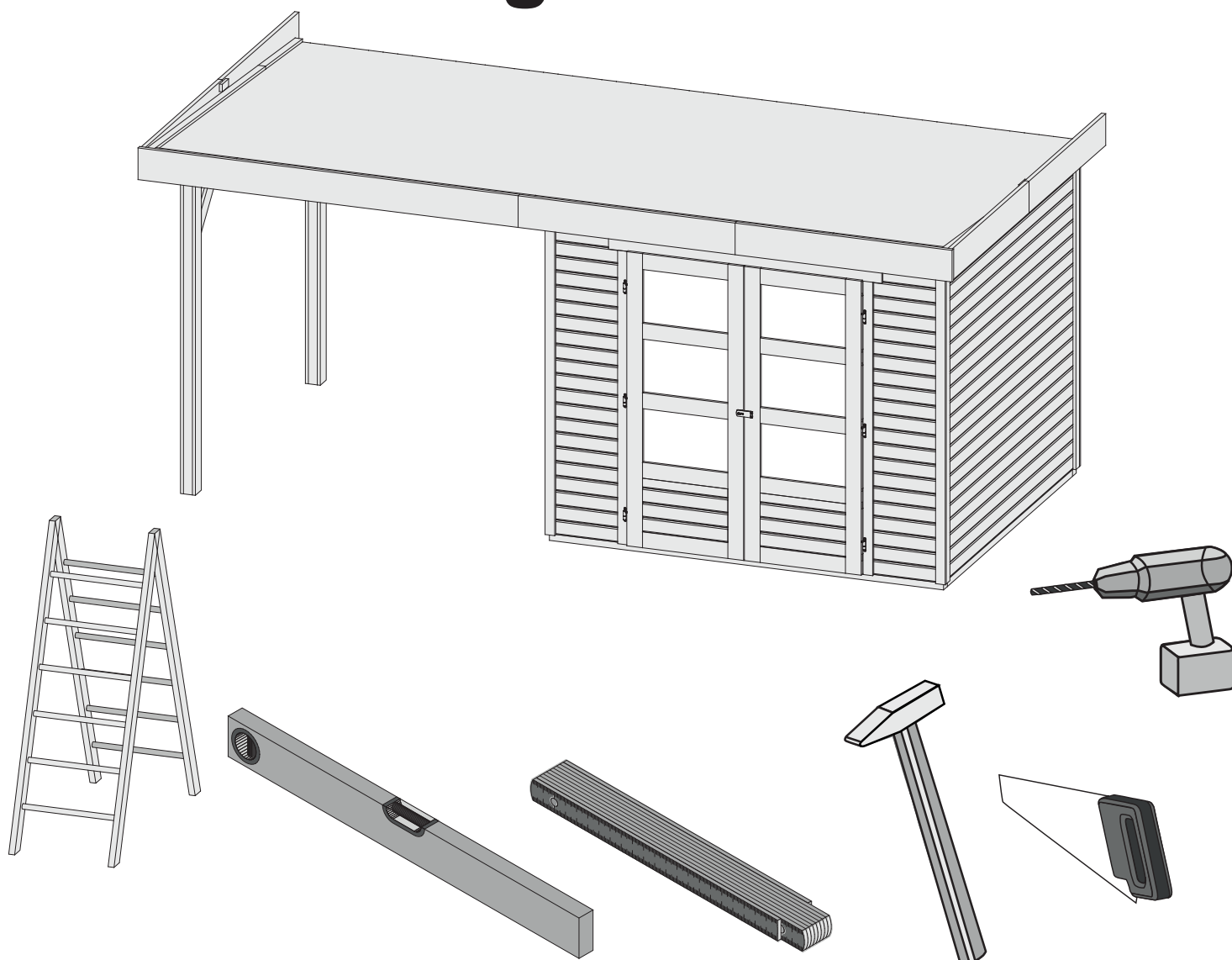

 **Aufbauanleitung**

 **notice de montage**

 **Building Instructions**

 **montagehandleiding**

 **Instrucciones de construcción**

 **Istruzioni per il montaggio**

 **Montážní návod**

 **Service-Hotline: +49 421 38693 33**



Vergleichen Sie zuerst die Materialliste mit Ihrem Paketinhalt! Bitte haben Sie Verständnis, dass Beanstandungen nur im nicht aufgebauten Zustand bearbeitet werden können!



En primer lugar, compare la lista de material con el contenido del paquete. Rogamos entienda que las reclamaciones sólo pueden ser tramitadas antes de montar el objeto!



Nejprve přezkontrolujte obsah balení podle materiálového listu! Mějte pochopení pro to, že případnou reklamaci se můžeme zabývat pouze tehdy, když díly nebudou smontované! Za pomoci tohoto seznamu můžete jednotlivé díly přiřadit k montážnímu návodu.



Vergelijk eerst de lijst van materialen met de inhoud van uw pakket! Reclamaties kunnen alleen in behandeling worden genomen zolang de onderdelen nog niet zijn gemonteerd!



First compare the list of materials with your package contents! Please understand that complaints can be processed in the non-built status only!



Commencez par comparer la liste du matériel avec le contenu de votre paquet! Sachez que nous traitons uniquement les réclamations concernant le matériel à l'état non monté!



Confrontate questa distinta materiali prima con il contenuto del pacchetto! Vi preghiamo di comprendere che eventuali reclami possono essere accolti solo prima del montaggio!



# 73766

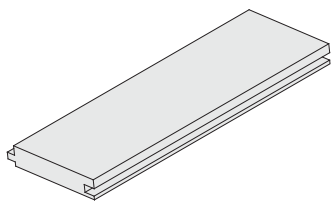

55 x U1	2390 x 96 x 16mm	ID 73291
42 x U2	478 x 96 x 19mm	ID 73741
42 x U3	2090 x 96 x 19mm	ID 43927
24 x U4	2380 x 96 x 19mm	ID 44696

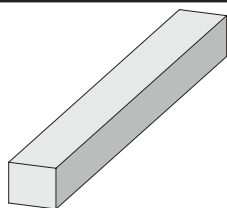

2 x B1	1755 x 36 x 18mm	ID 73740
8 x B2	100 x 45 x 18mm	ID 19114
6 x B3	240 x 45 x 18mm	ID 16392
1 x B4	1390 x 45 x 18mm	ID 58371
1 x B5	1737 x 45 x 18mm	ID 19205
2 x B6	1755 x 45 x 18mm	ID 59227
6 x B7	1800 x 45 x 18mm	ID 19546
2 x B8	1760 x 58 x 18mm	ID 71960
4 x B9	1980 x 58 x 18mm	ID 38947
4 x B10	2100 x 58 x 18mm	ID 28029
3 x B11	2085 x 95 x 18mm	ID 41089
3 x B12	2100 x 95 x 18mm	ID 11427
15 x B13	2343 x 95 x 18mm	ID 57801
1 x B14	1650 x 120 x 18mm	ID 58005
4 x B15	1225 x 190 x 26mm	ID 73804
2 x B16	1310 x 190 x 26mm	ID 73805
1 x B17	2300 x 190 x 26mm	ID 63005
2 x B18	90 x 54 x 36mm	ID 61513
3 x B19	2343 x 95 x 36mm	ID 55860
5 x B20	1950 x 45 x 38mm	ID 41511
2 x B21	2000 x 45 x 38mm	ID 18358
4 x B22	2380 x 60 x 40mm	ID 44694



1 x P1	2090 x 172 x 19mm	ID 61300
1 x P2	2090 x 172 x 19mm	ID 61301

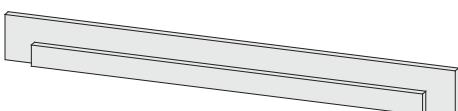

1 x H1	1650 x 120 x 36mm	ID 73738
--------	-------------------	----------

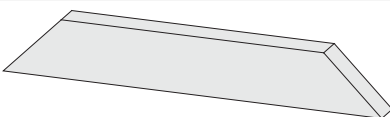

4 x G1	540 x 95 x 18mm	ID 17869
--------	-----------------	----------

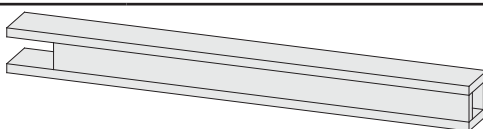

2 x G2	2025 x 95 x 90mm	ID 61523
--------	------------------	----------

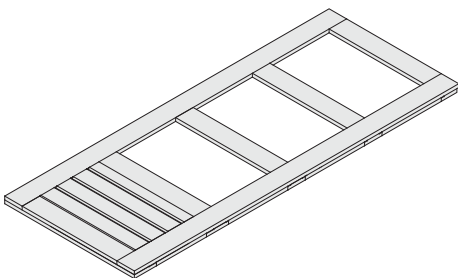

1 x D1	1765 x 705 x 36mm	ID 73736
--------	-------------------	----------

1 x D2	1765 x 705 x 36mm	ID 73737
--------	-------------------	----------

1 x



ID 16034

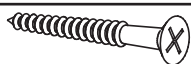

10 x	4 x 16mm	ID 3690
------	----------	---------

100 x	4 x 25mm	ID 5841
-------	----------	---------

750 x	4 x 30mm	ID 3686
-------	----------	---------

850 x	4 x 50mm	ID 3688
-------	----------	---------

80 x	4 x 70mm	ID 3689
------	----------	---------

50 x	4,5 x 80mm	ID 9204
------	------------	---------

530 x



ID 3948

2 x

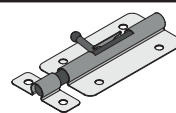

ID 3709

1 x

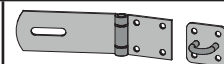

ID 3724

6 x

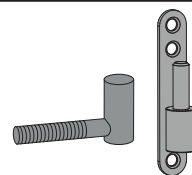

ID 3717

10 x

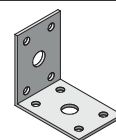

ID 21292



Kleber  
Colle  
Glue  
Lijm

Pegamento  
Colla  
Kliih

1 x

ID 55202

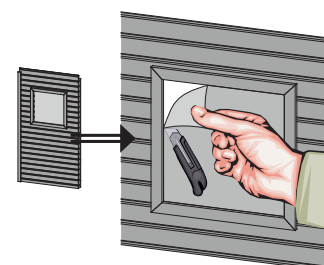

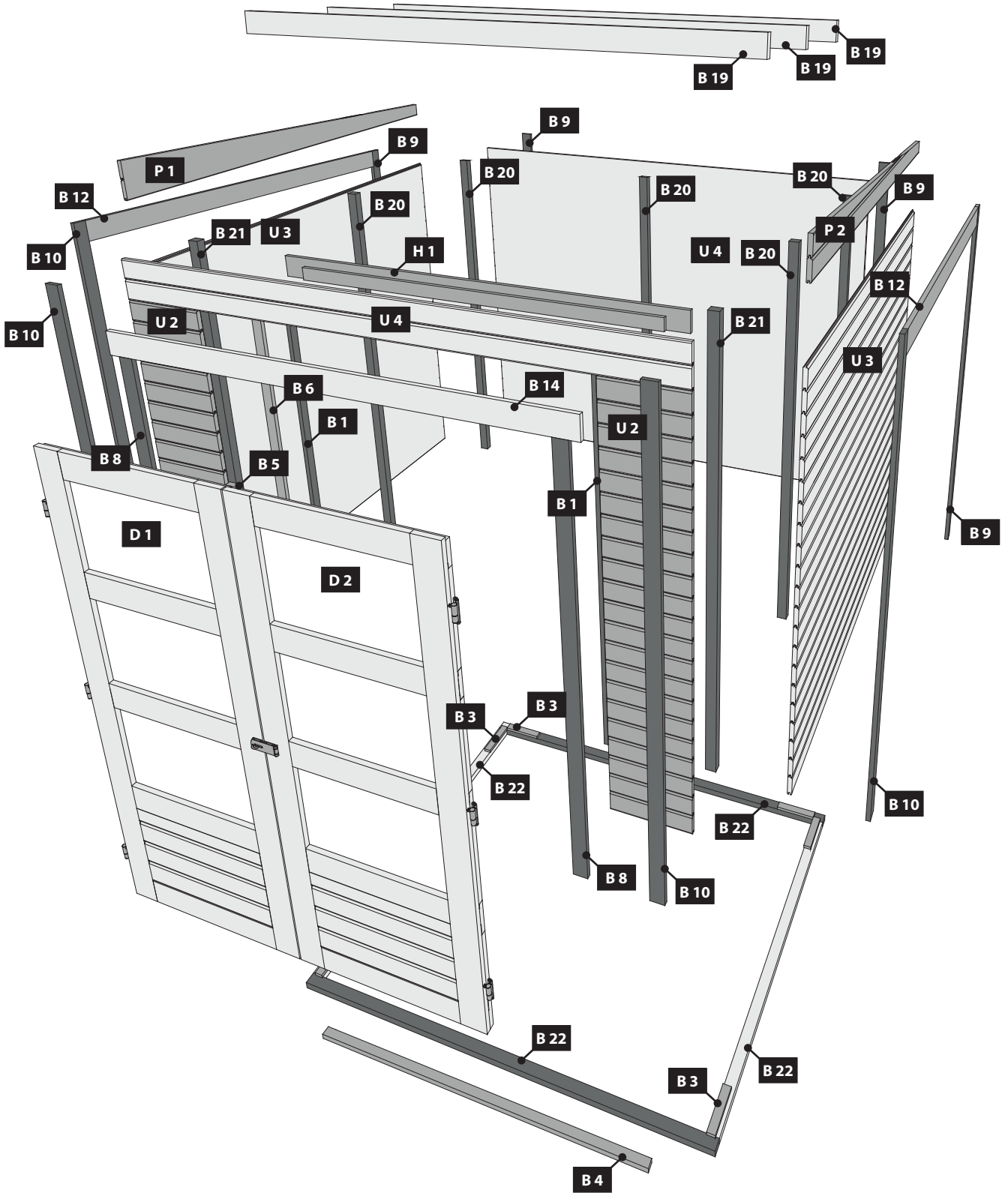
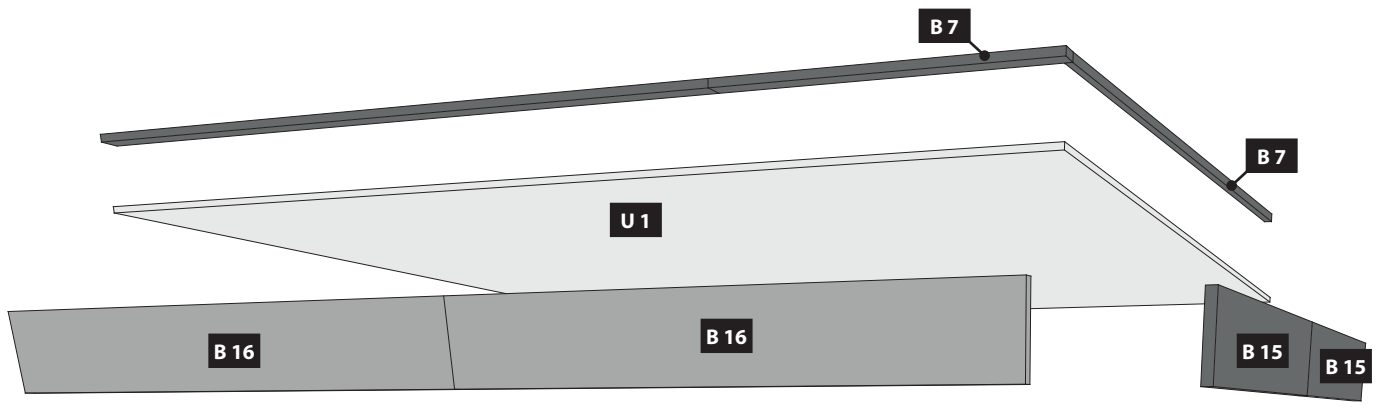

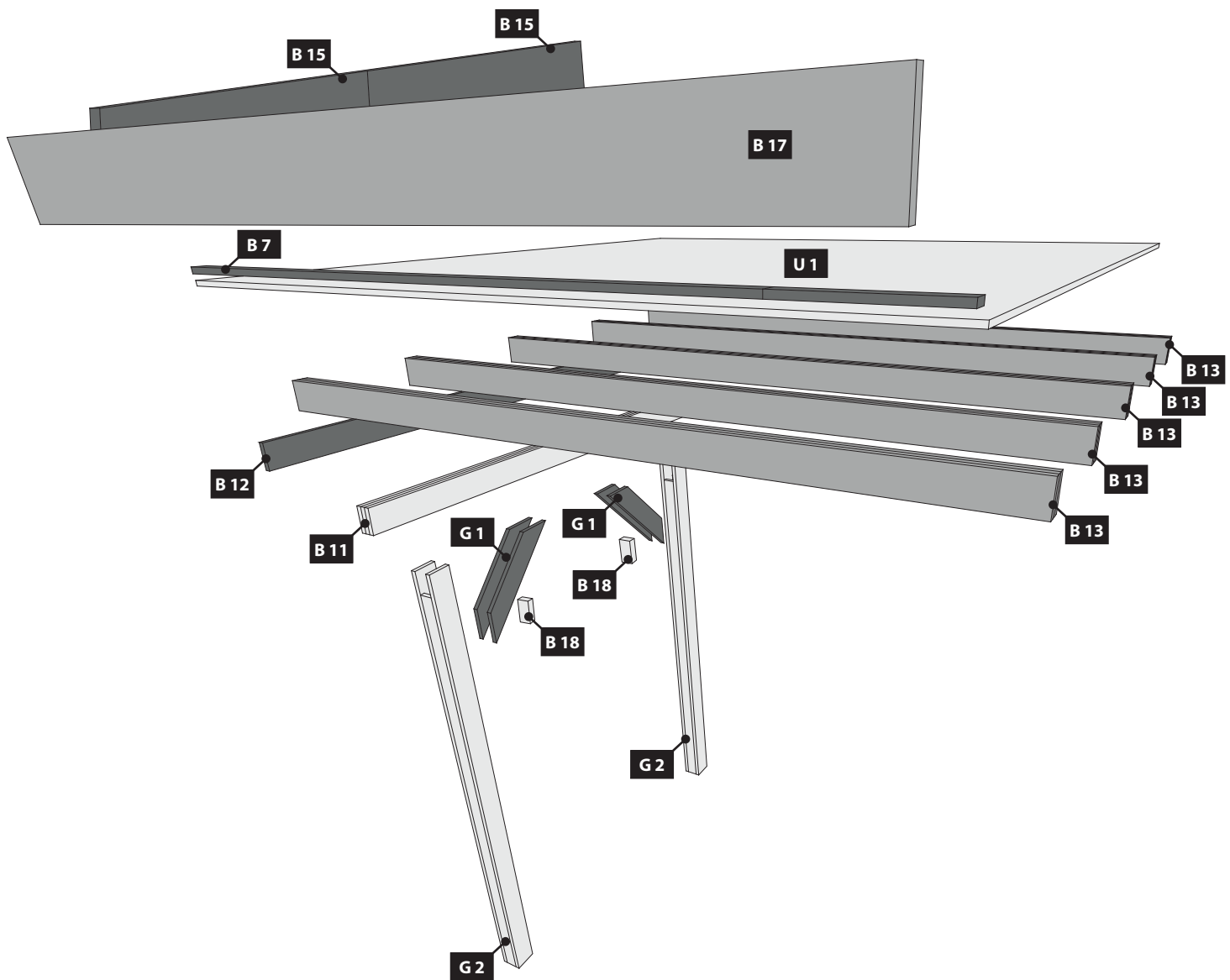

### *Hinweis*

Die Pfosten dieses Produkts sollten fest mit dem Untergrund verbunden werden. Dazu empfehlen wir H-Pfostenanker. Diese sollten erst nach dem Aufbau dieses Produkts endgültig mit Beton versehen werden. **Die H-Pfostenanker und das zugehörige Befestigungsmaterial sind nicht im Lieferumfang dieses Produkts enthalten.**

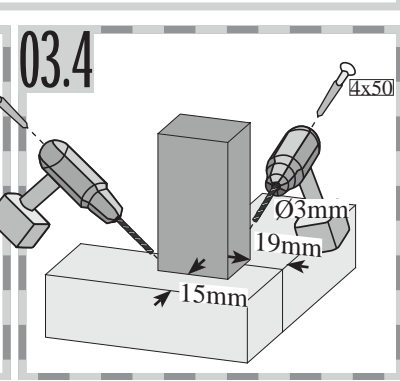
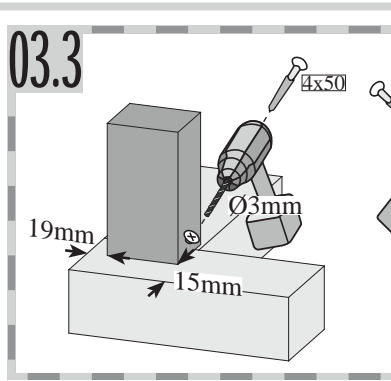
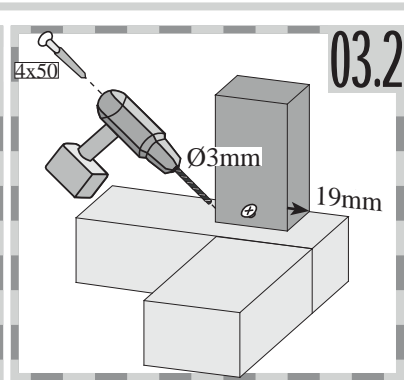
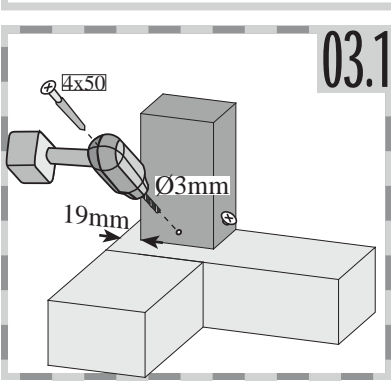
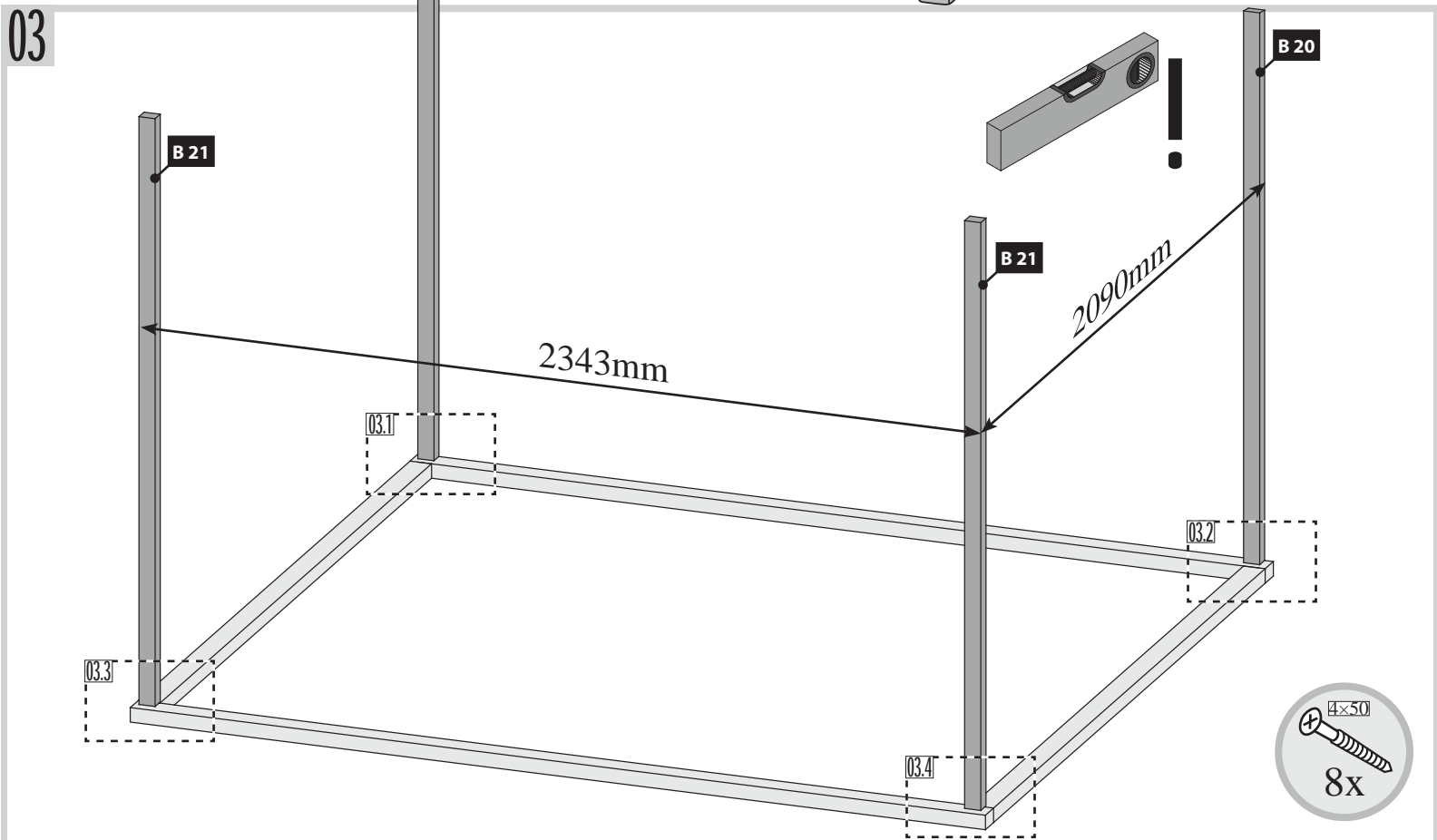
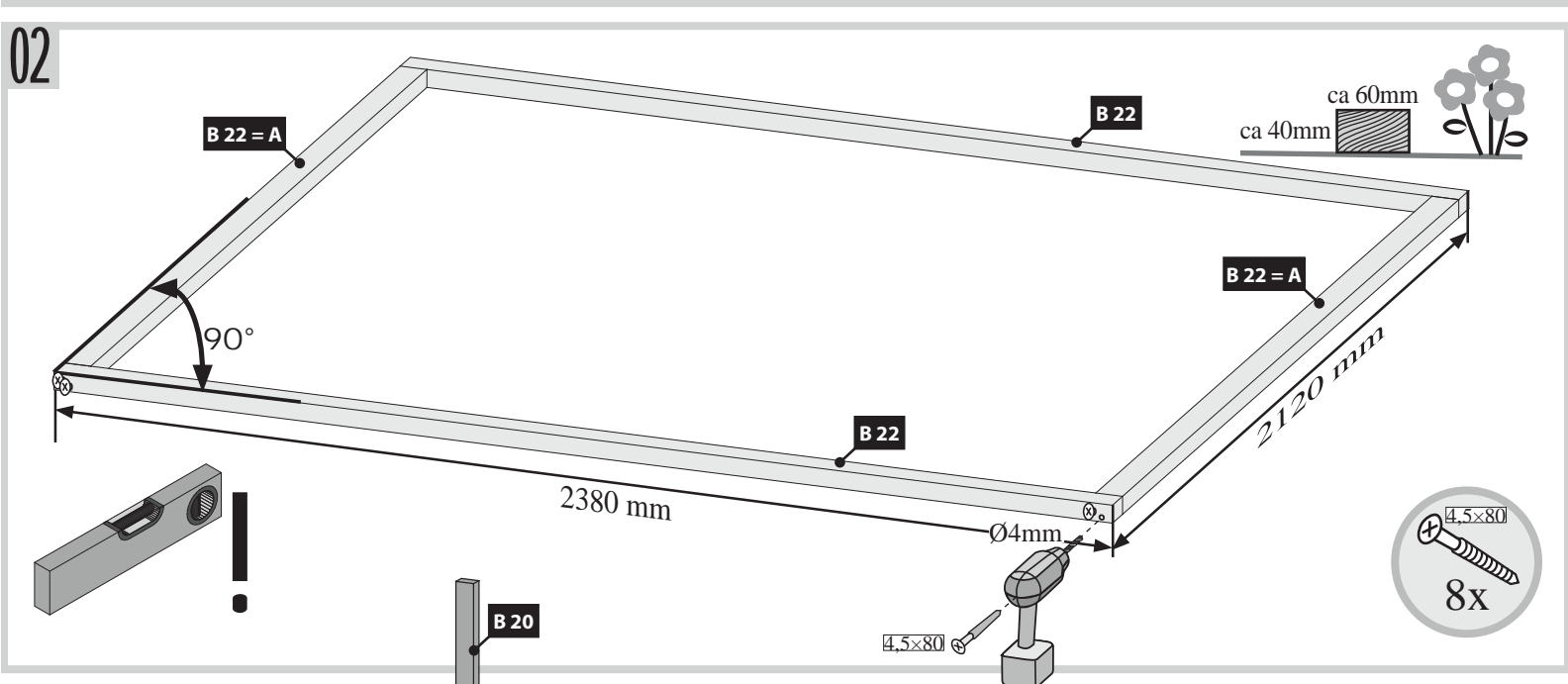
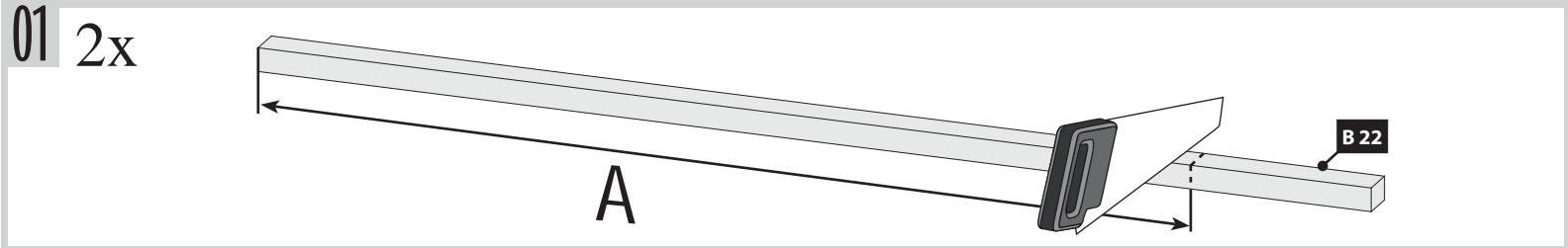

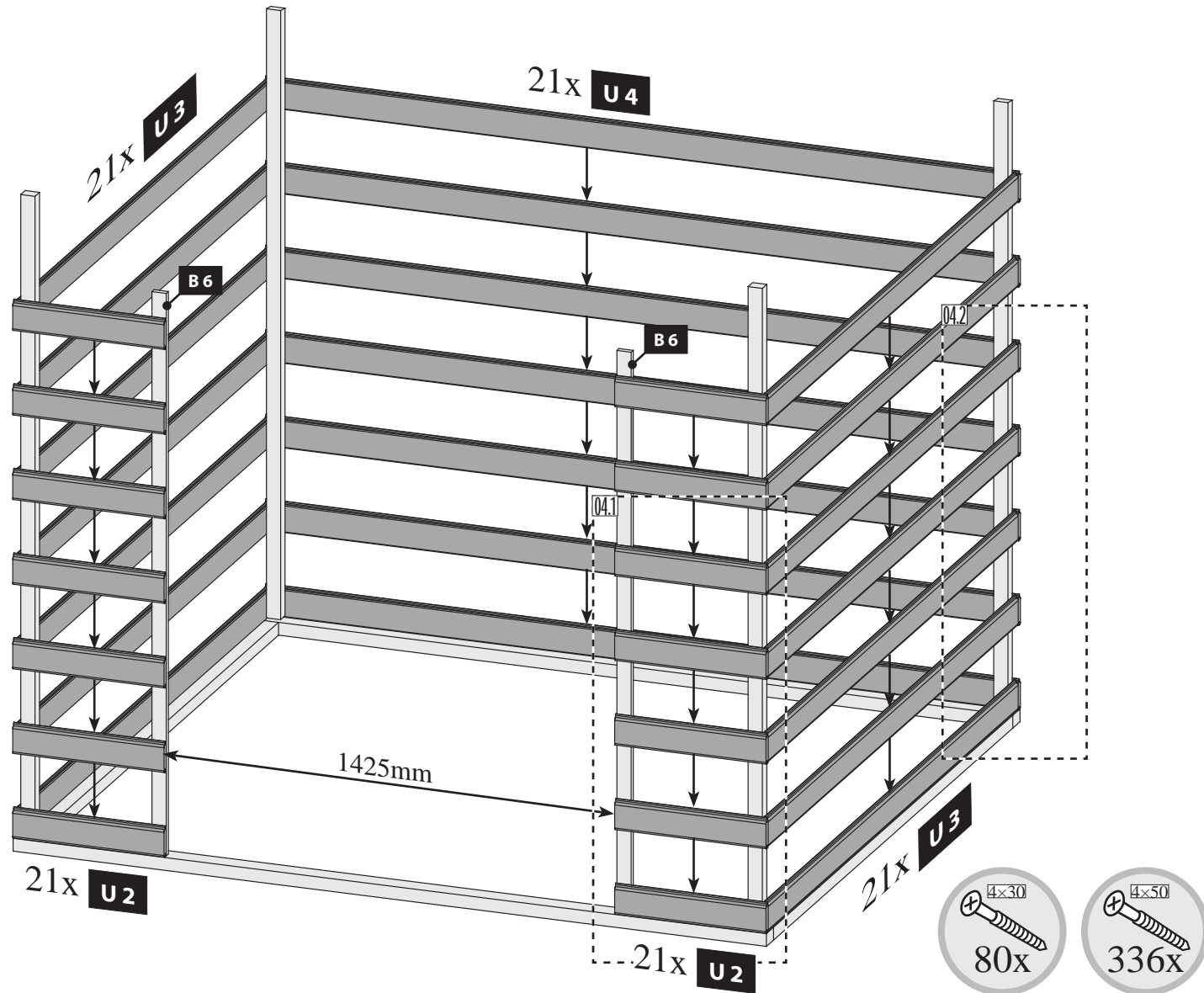

04.1

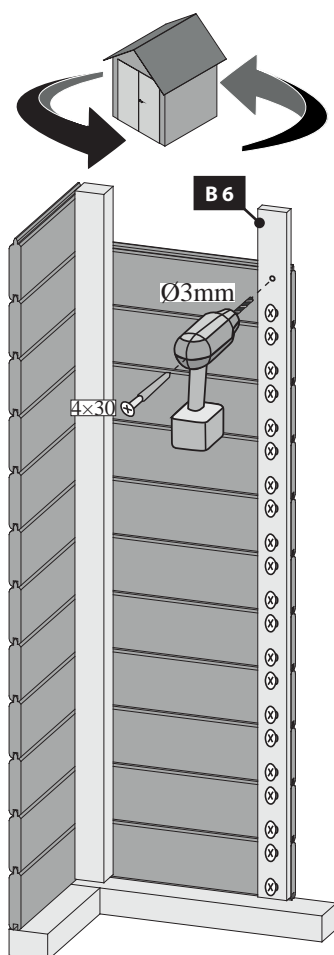
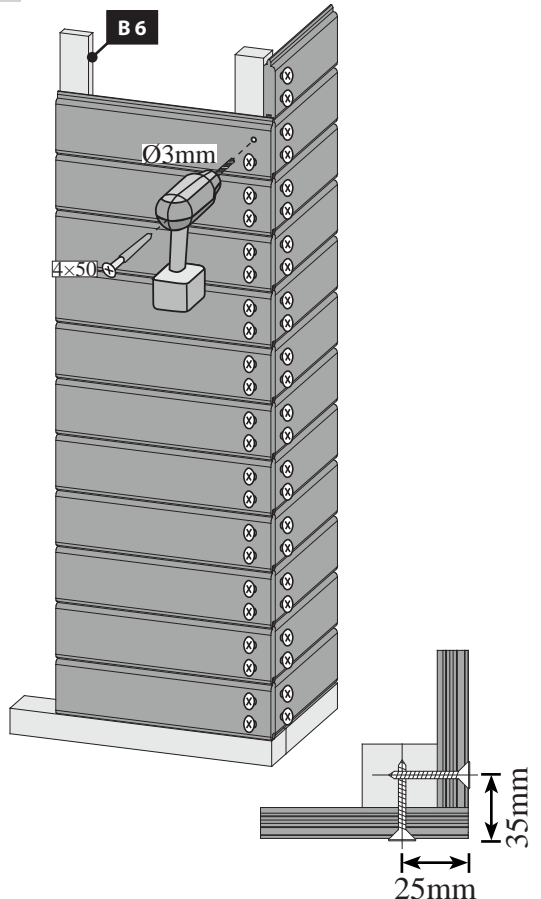

04.2

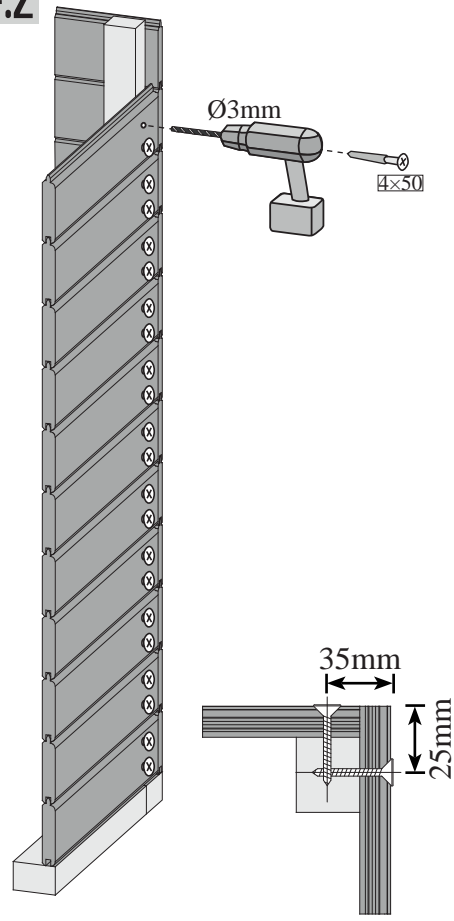

05

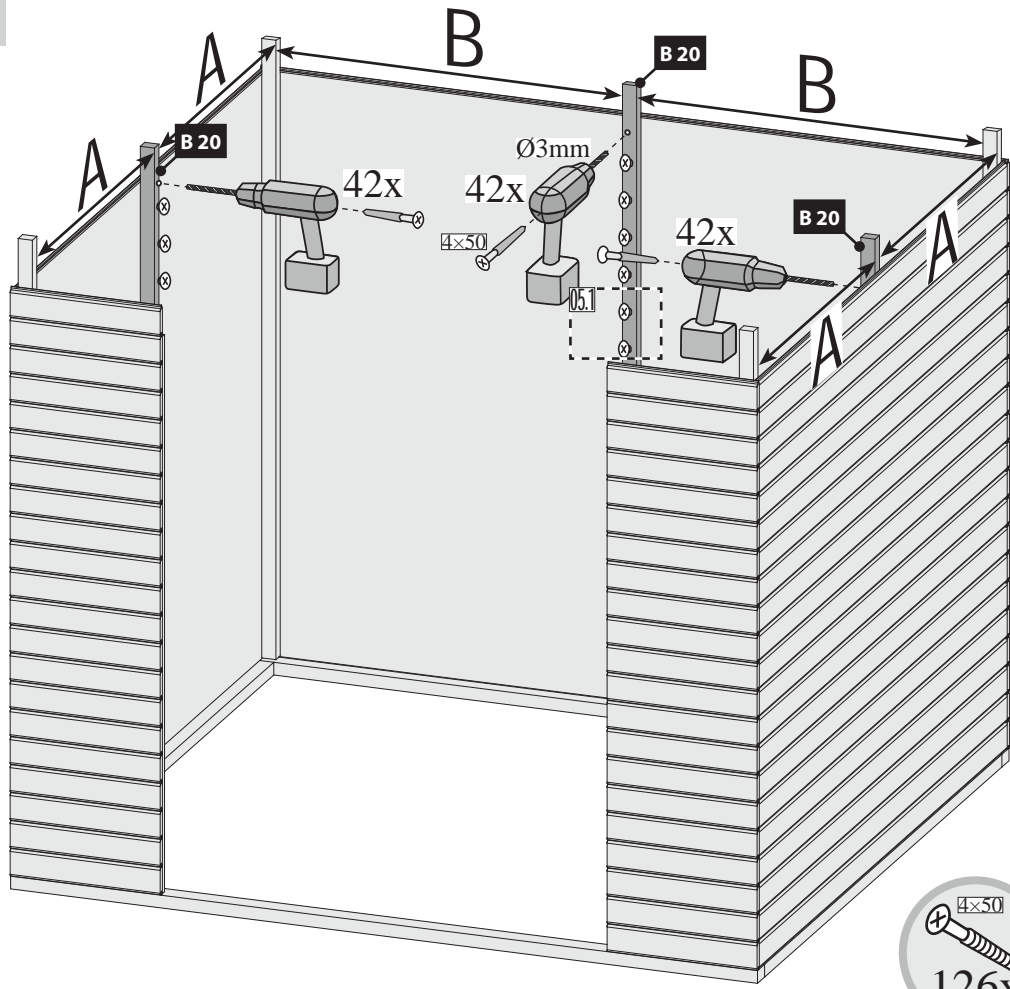

05.1

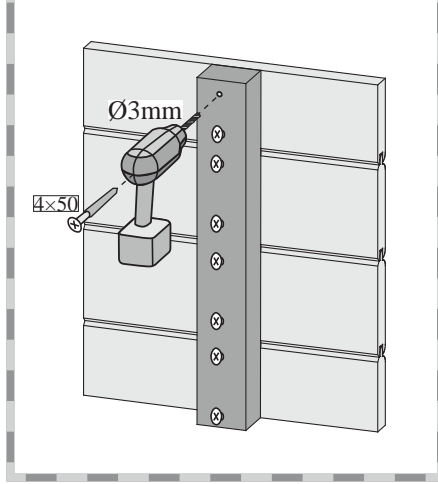

06

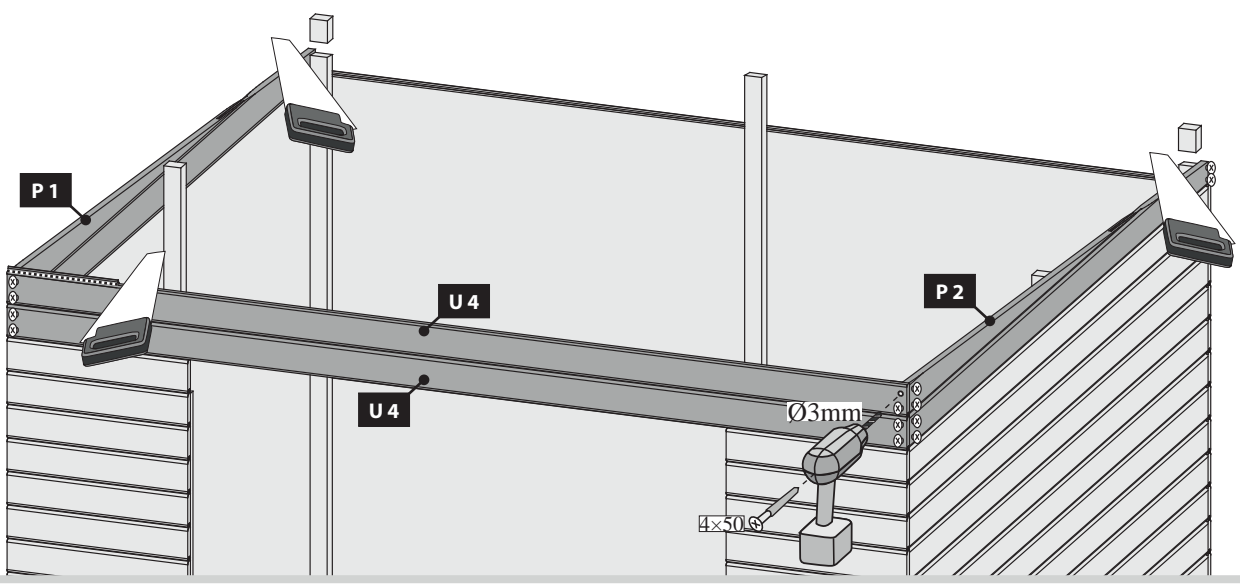

07

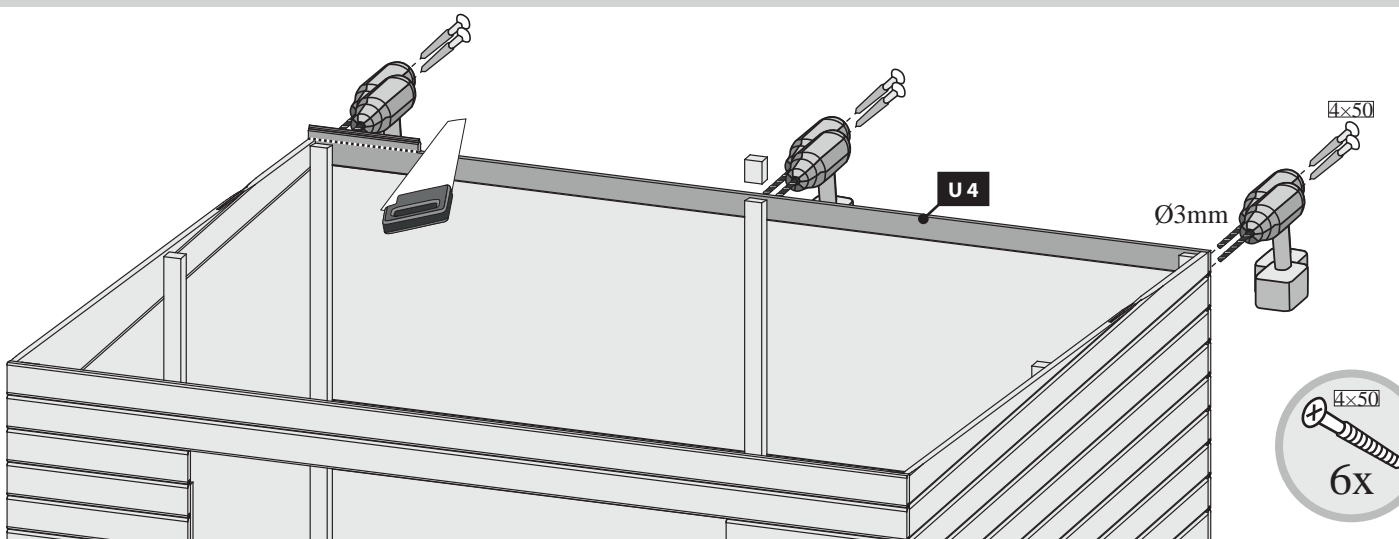

08

!!! A=B !!!

!!! C=D !!!

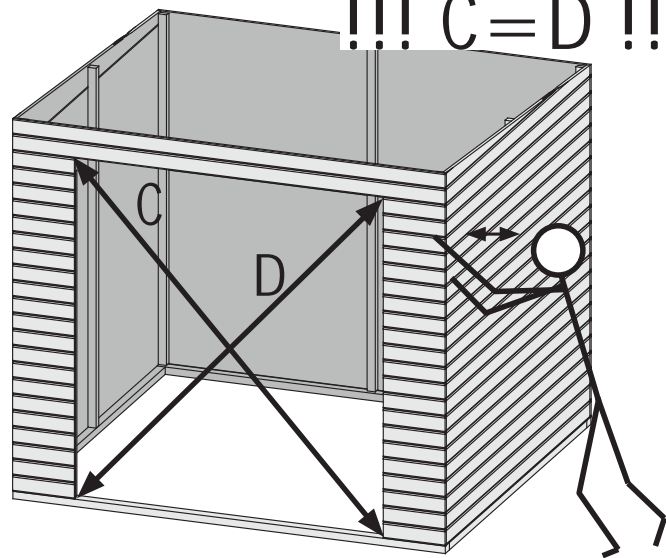
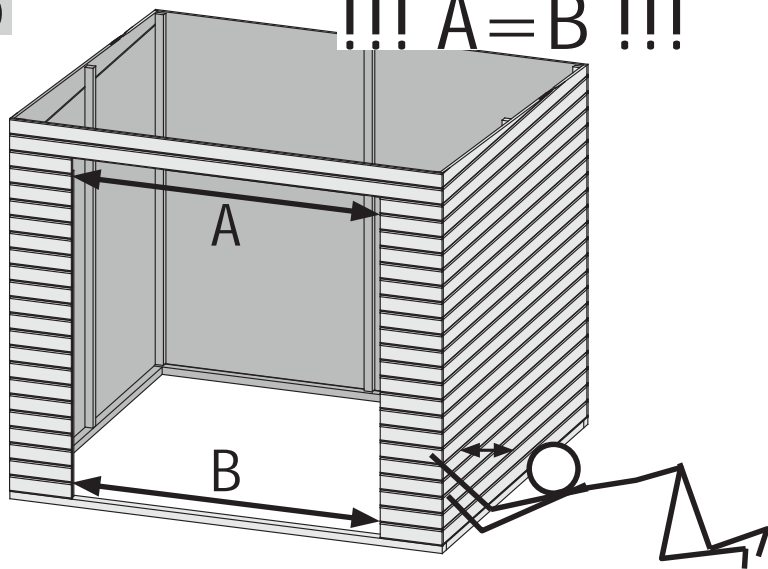

09

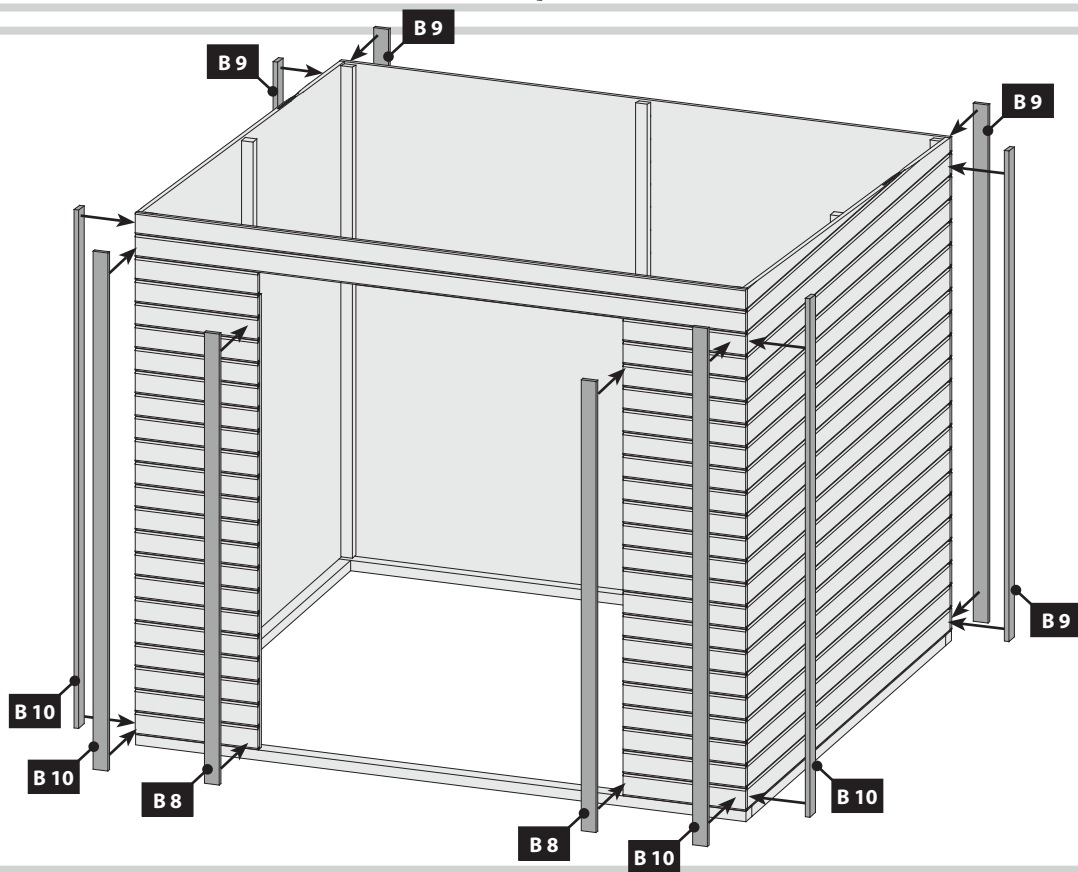

10

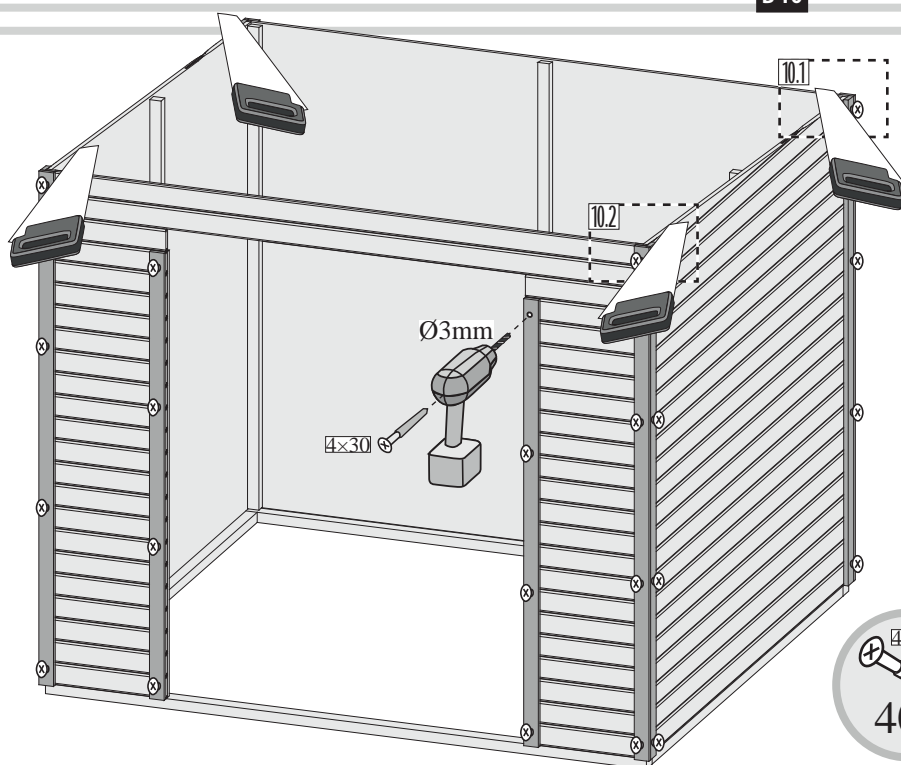

10.1

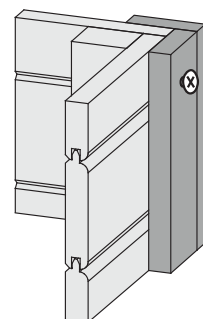

10.2

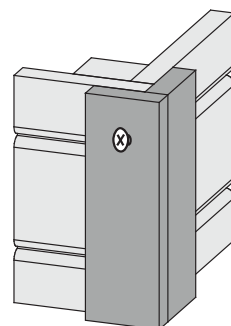



11

Affleurement!  
Gelijk!  
Aras!  
Flush!  
Combacia!

Affleurement!  
Gelijk!  
Aras!  
Flush!  
Combacia!

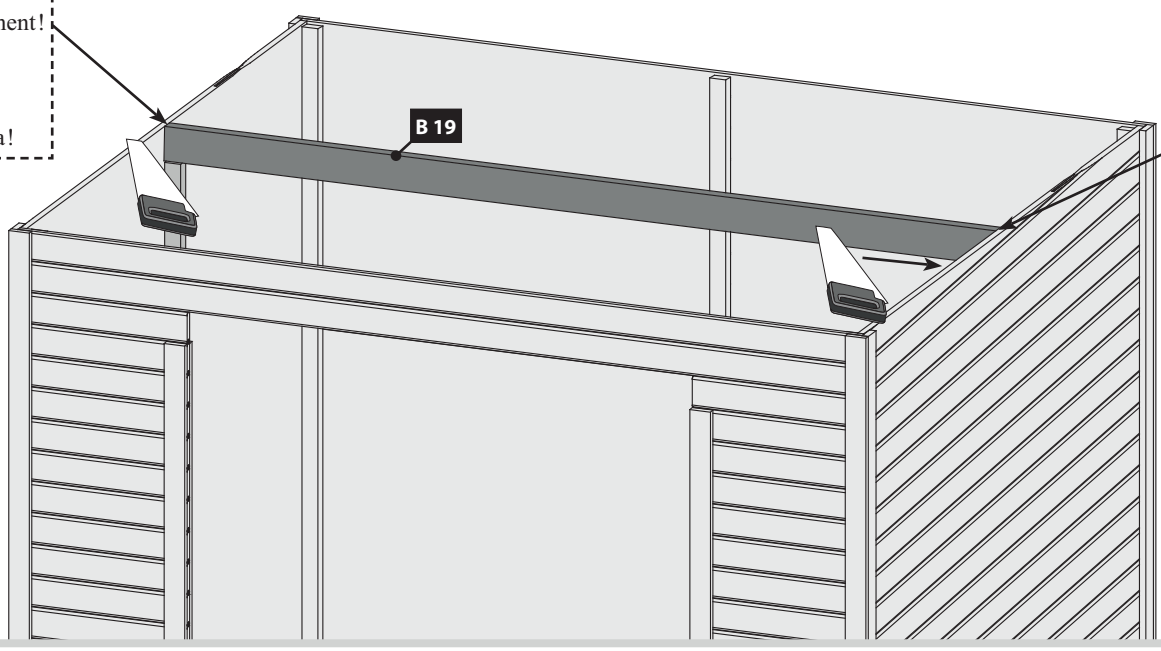

12

!!! A=B !!! C=D !!!

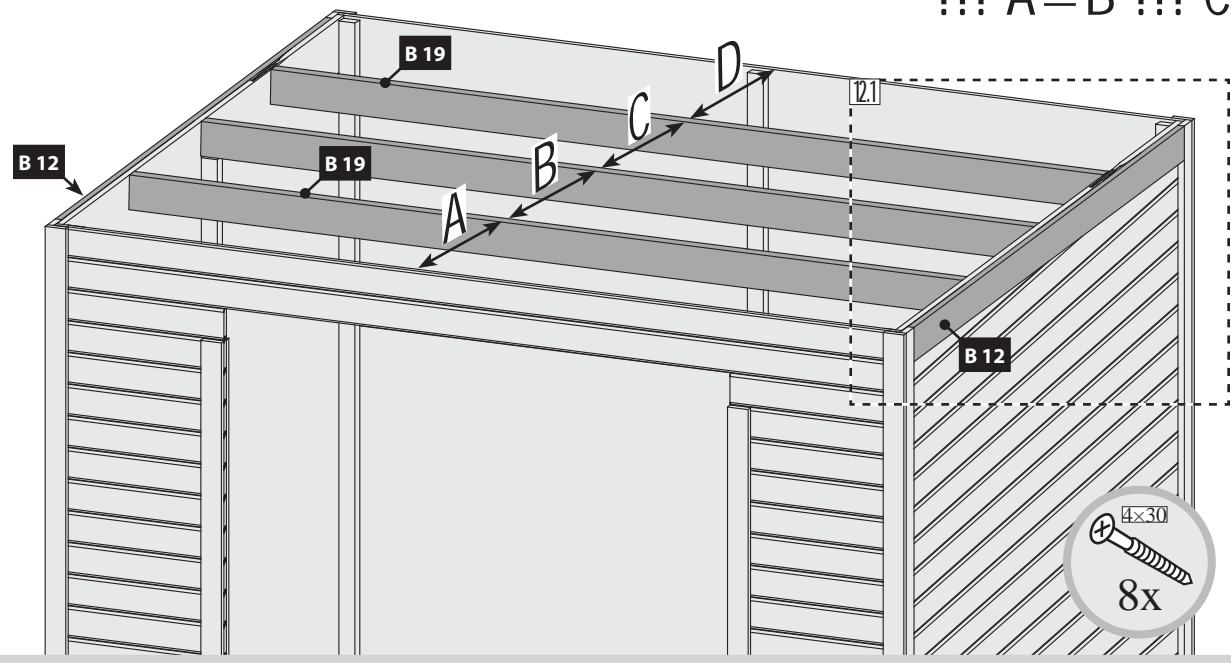

12.1-1

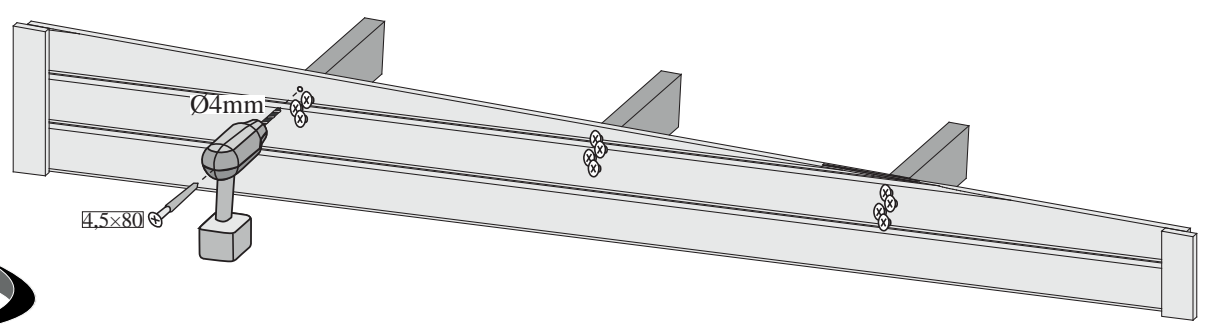
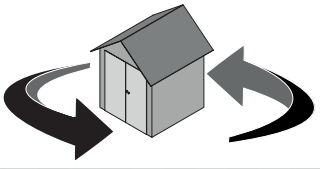

12.1-2

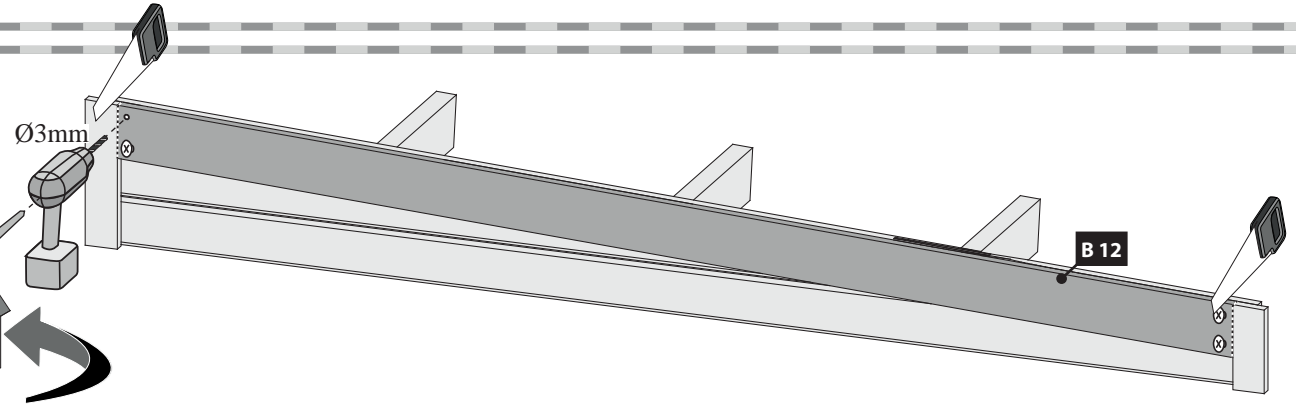
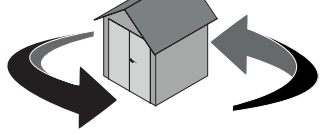

13 1x

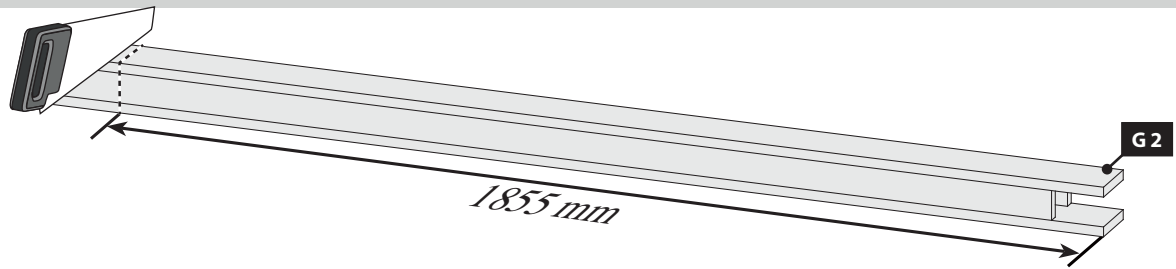

14 1x

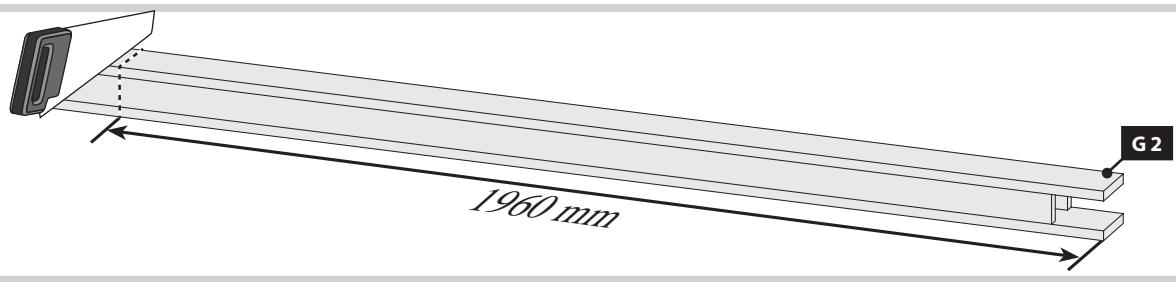

15 2x

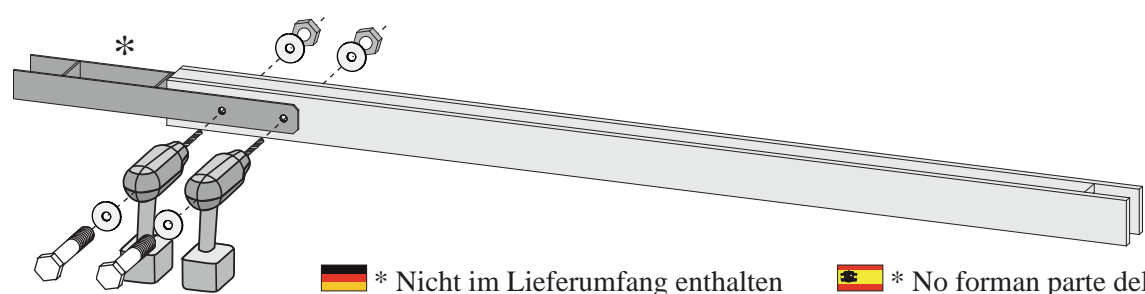

- \* Nicht im Lieferumfang enthalten
- \* No forman parte del suministro
- \* Niet bijgeleverd
- \* Non incluso
- \* Not included
- \* V ceně není zahrnuto
- \* Non comprises dans la livraison

16

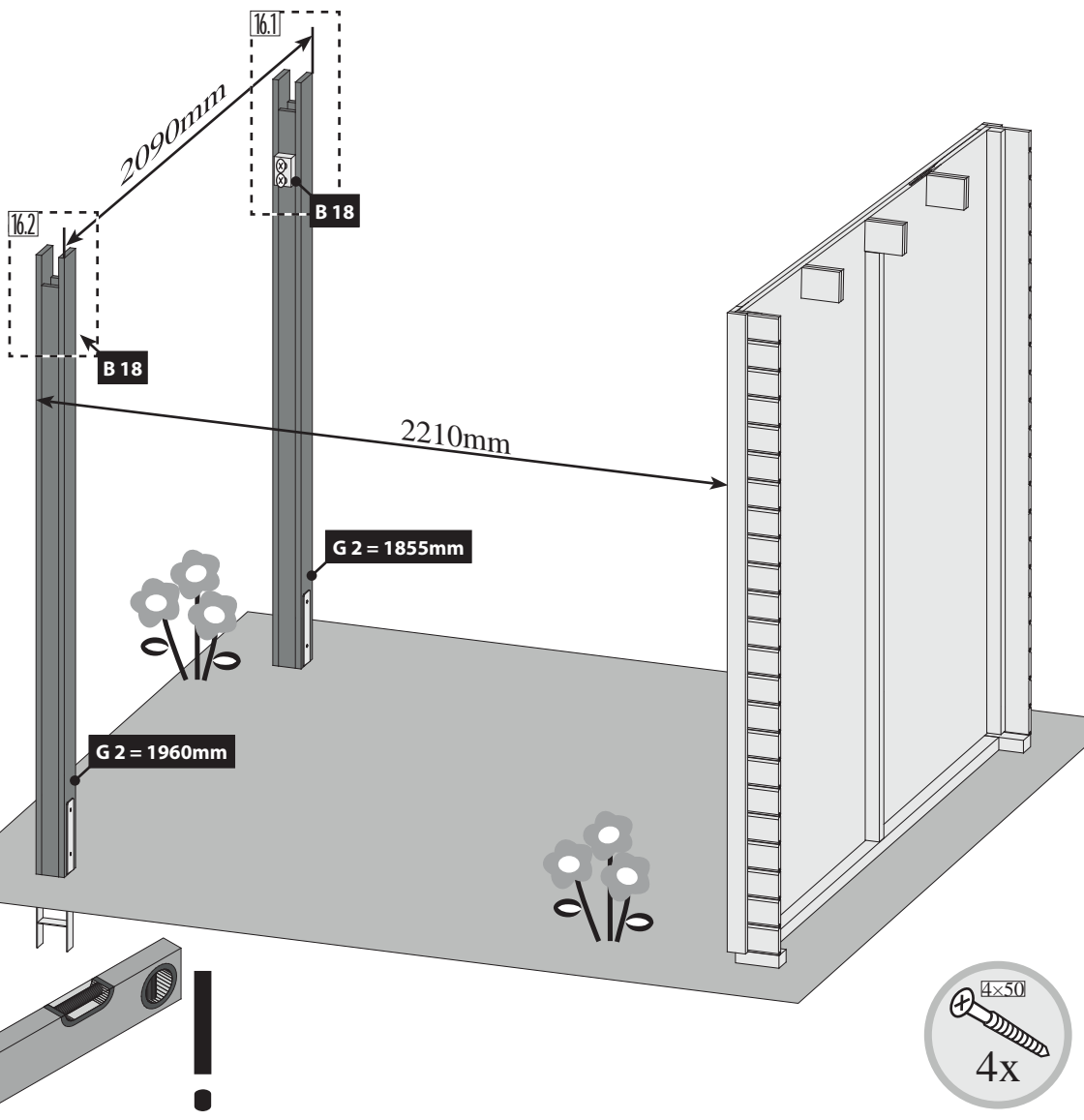

16.1

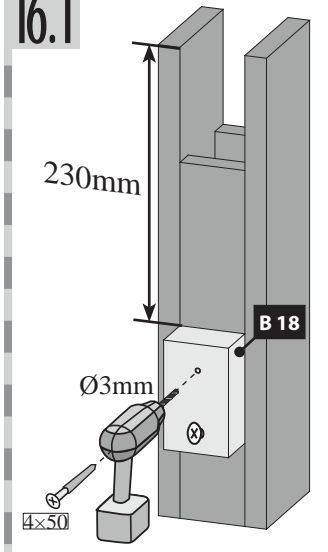

16.2

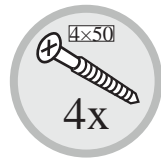
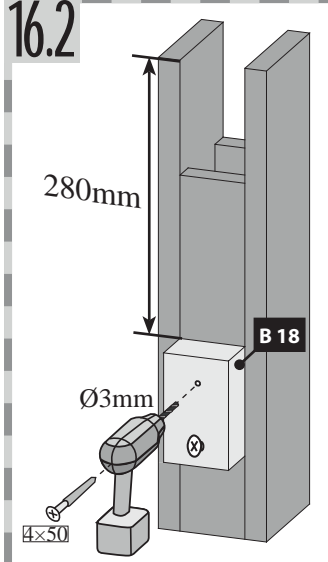

17 5x

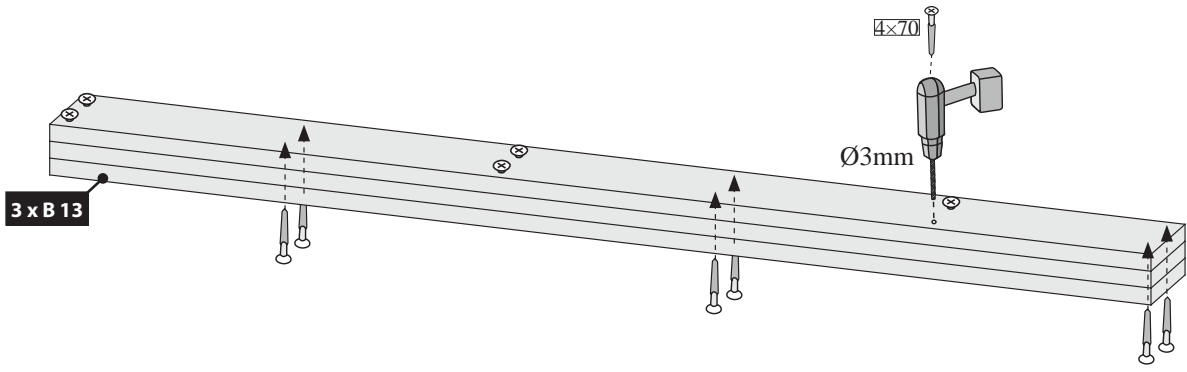

Bündig!  
Affleurement!  
Gelijk!  
Aras!  
Flush!  
Combacia!  
Flush!

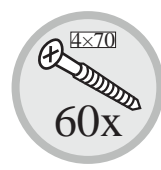

18

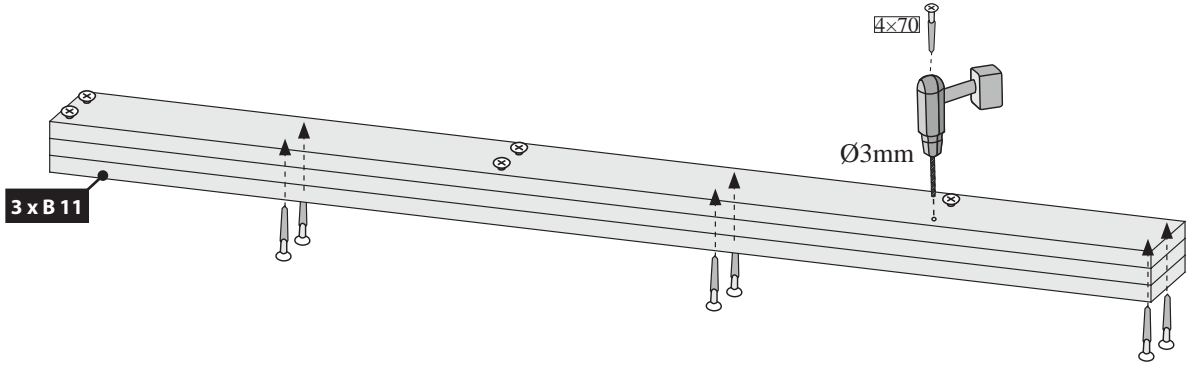

Bündig!  
Affleurement!  
Gelijk!  
Aras!  
Flush!  
Combacia!  
Flush!



19

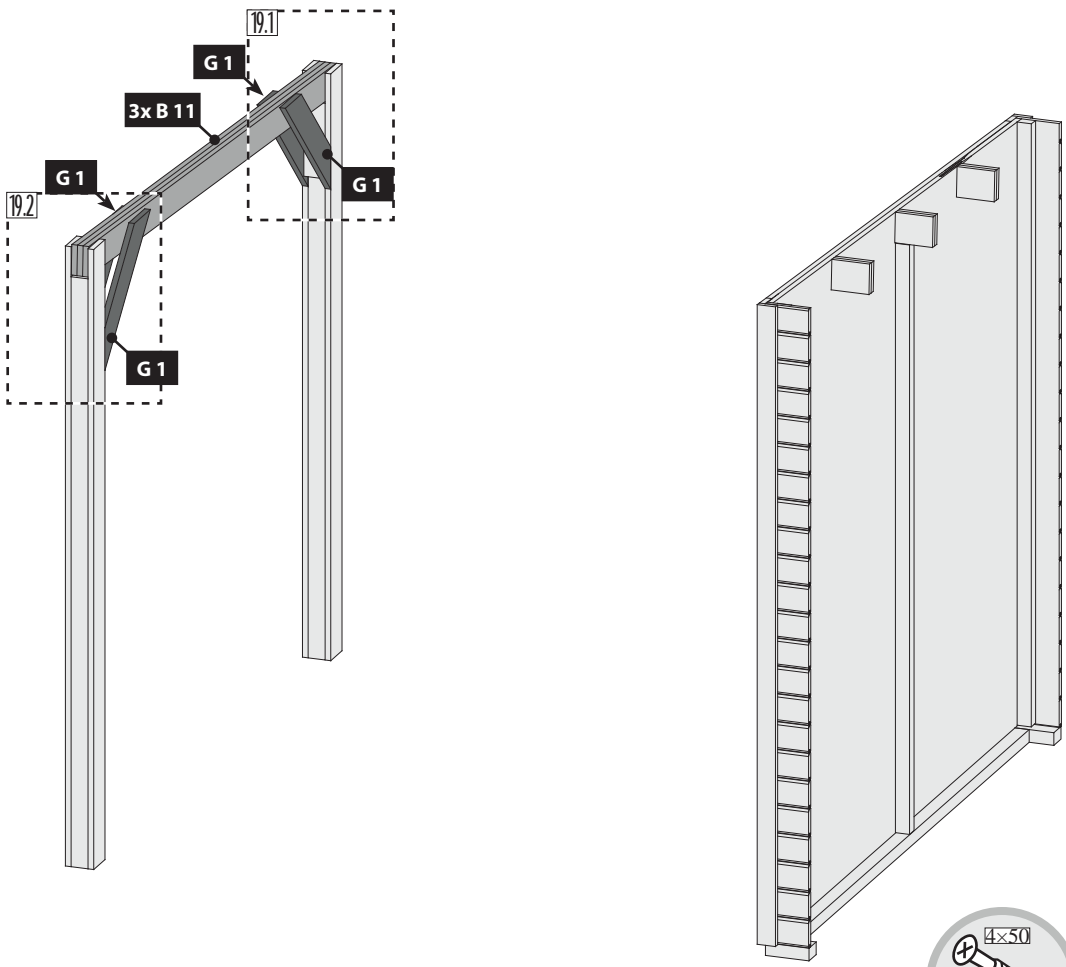

19.1

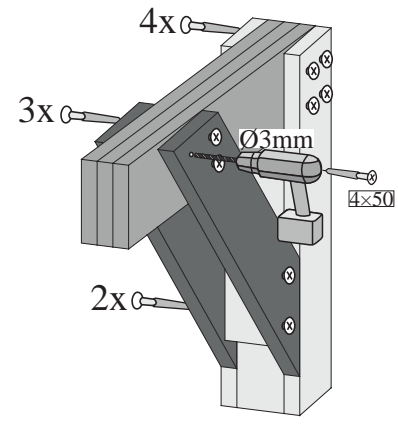

19.2

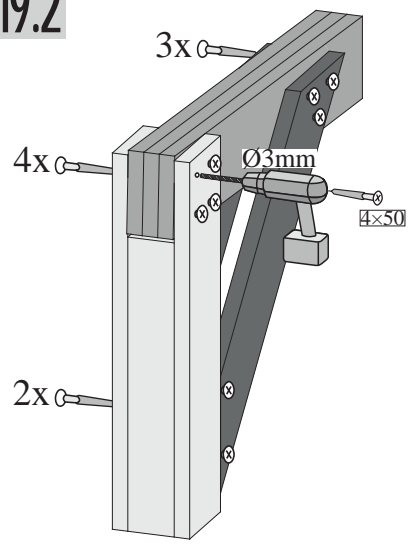

20

!!! A=B !!! C=D !!!

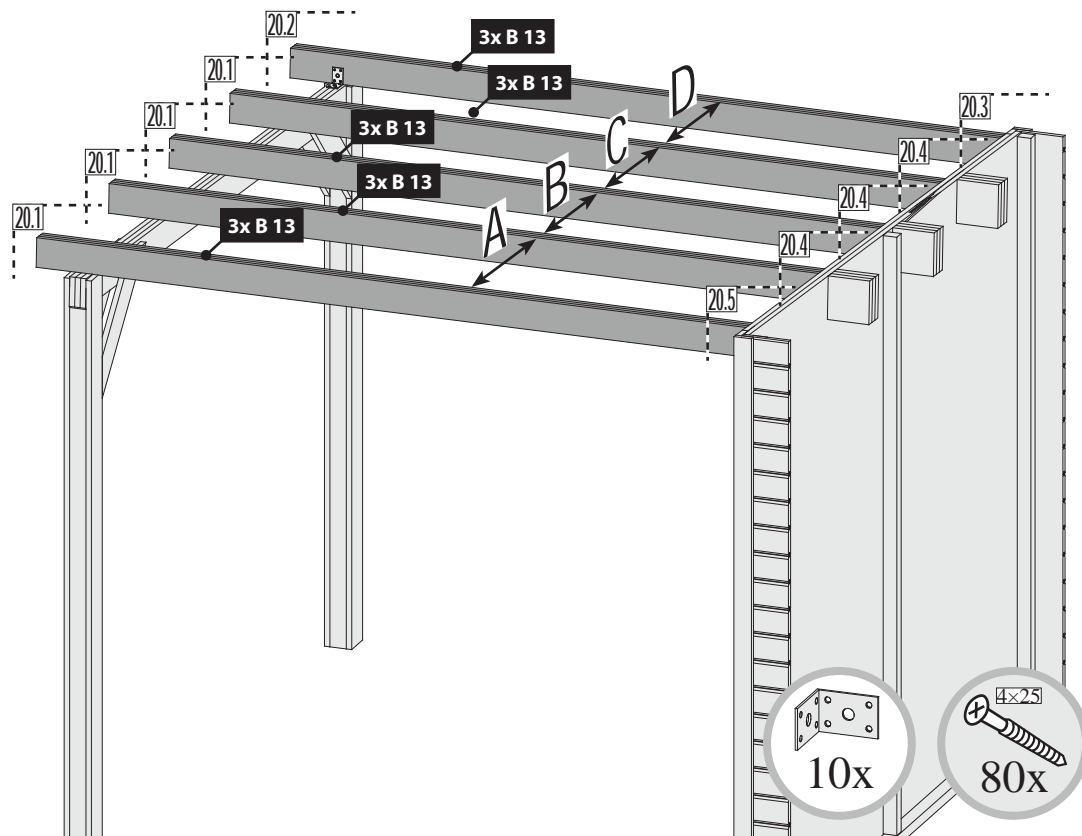

20.1

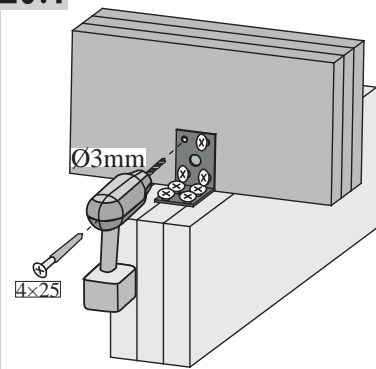

20.2

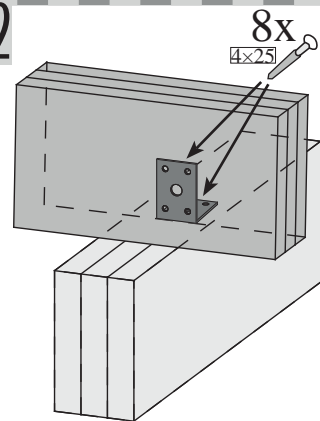

20.3

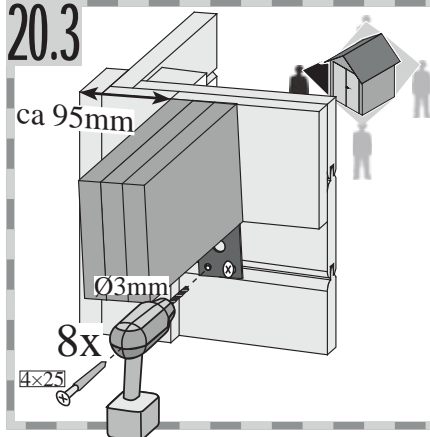

20.4

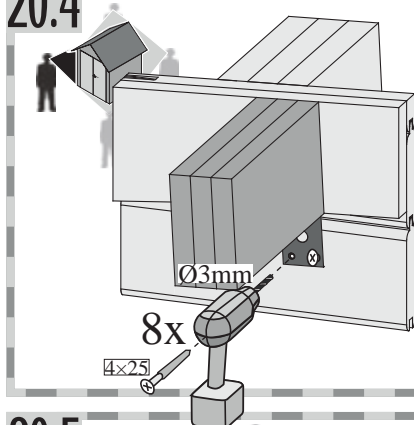

20.5

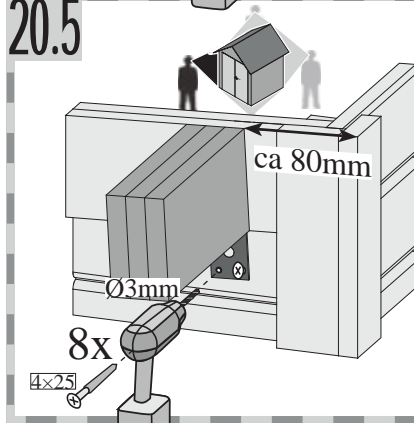



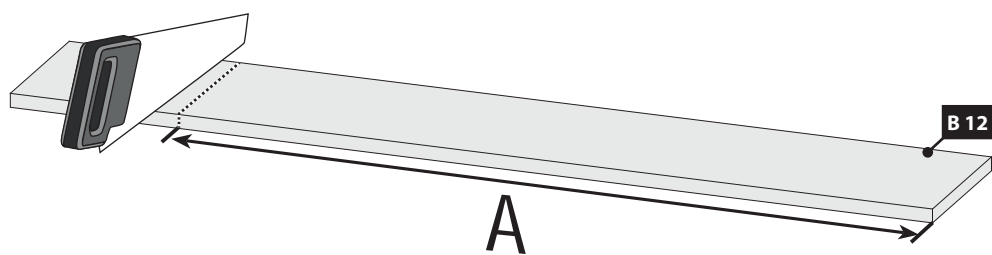

21

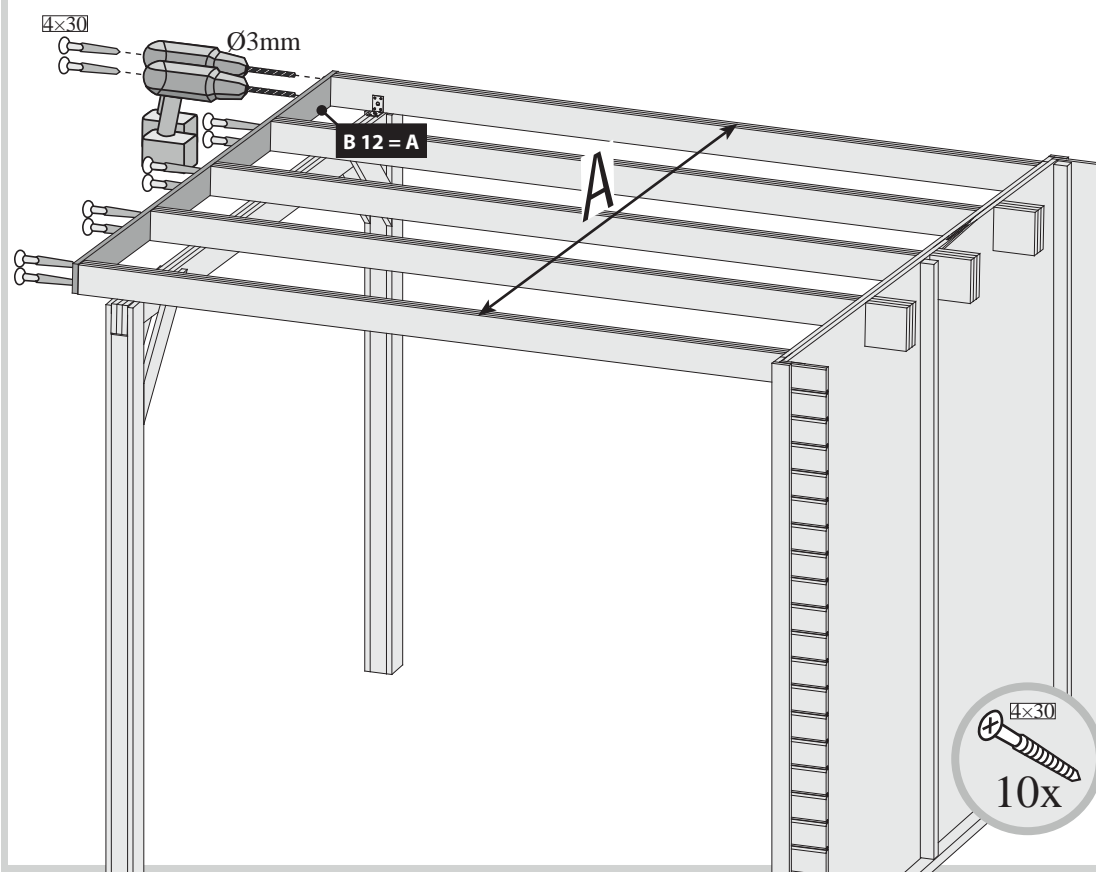

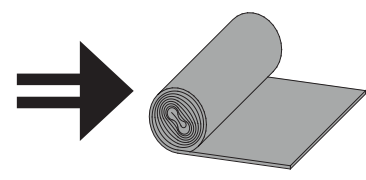
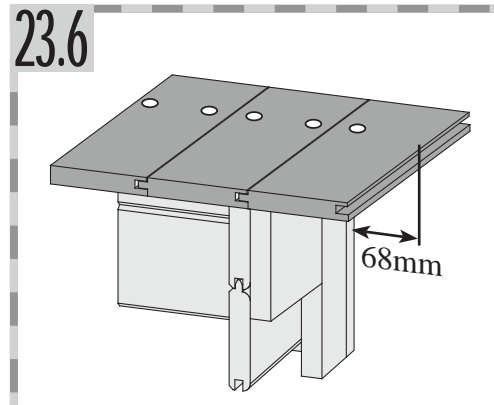
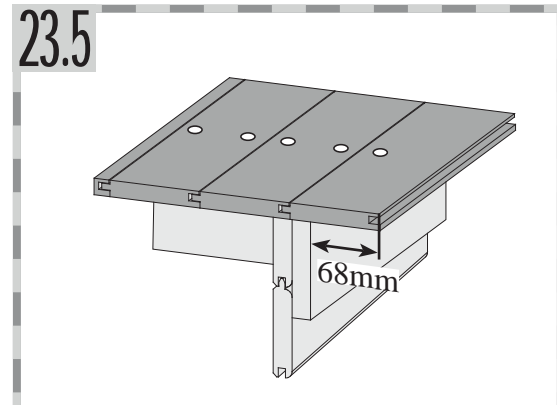
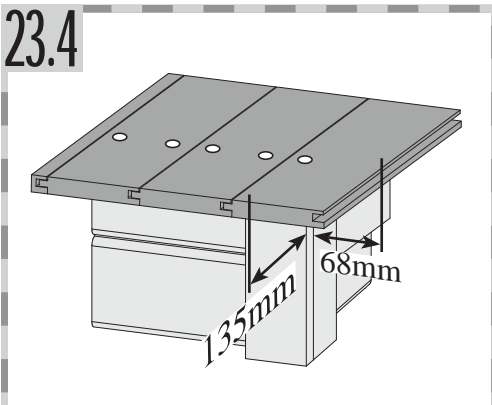
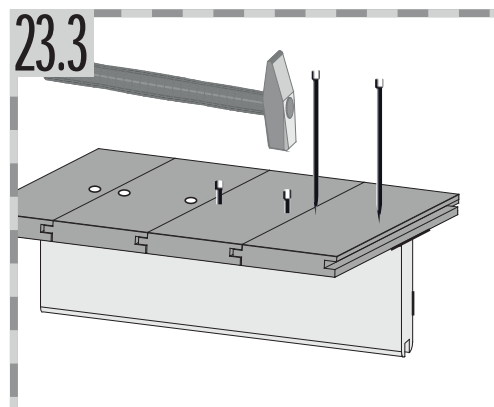
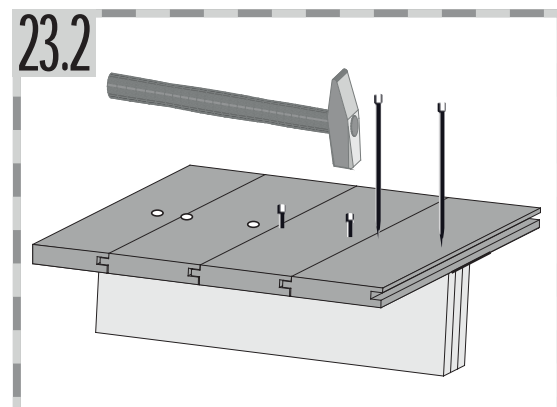
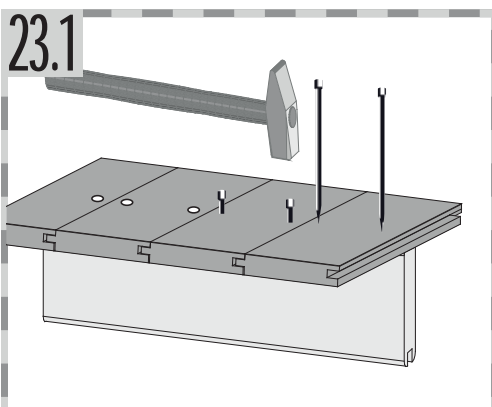
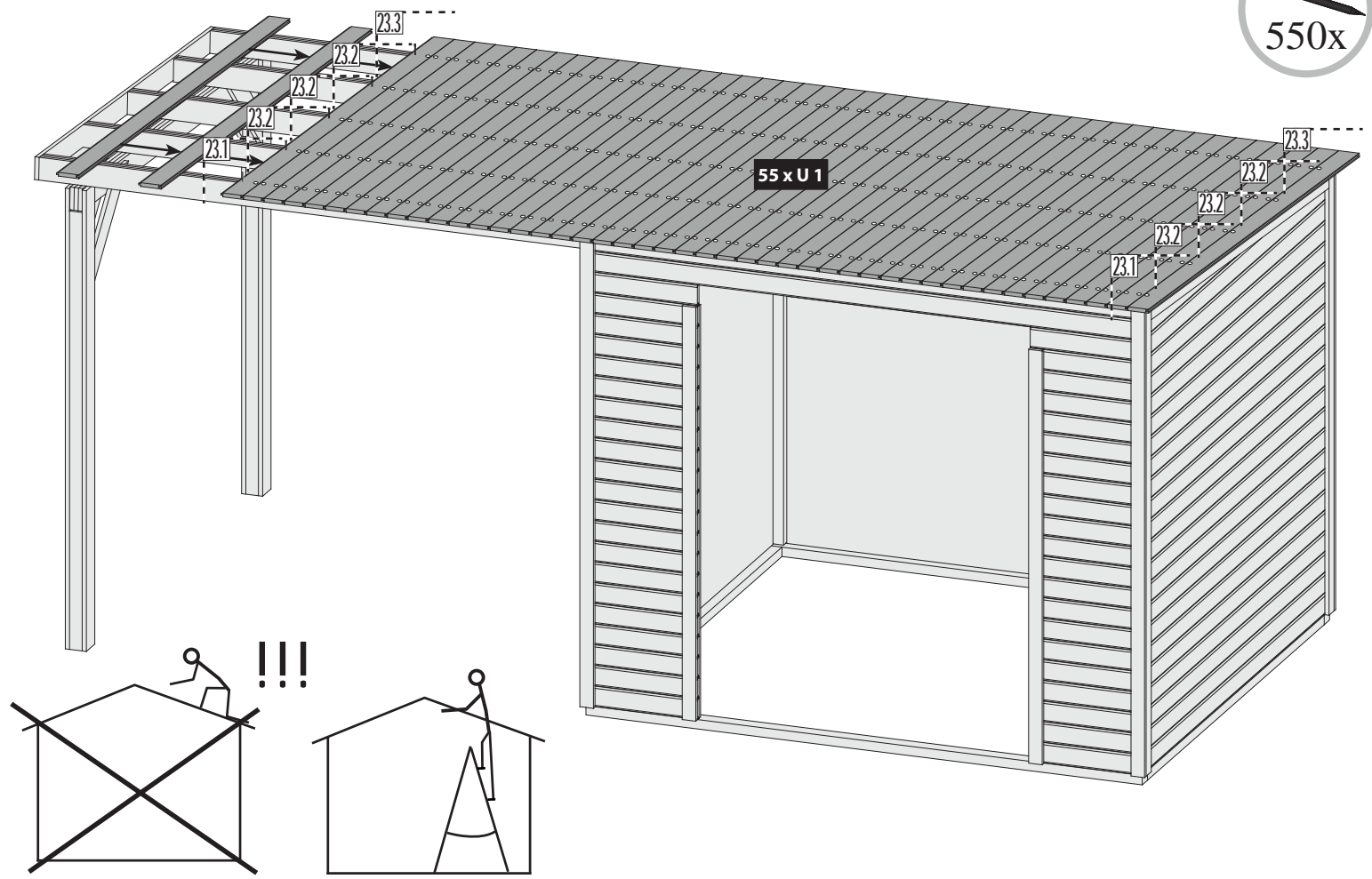

22





-  Nicht im Lieferumfang enthalten
-  Niet bijgeleverd
-  Not included
-  Non comprises dans la livraison

-  No forman parte del suministro
-  Non incluso
-  V ceně není zahrnuto

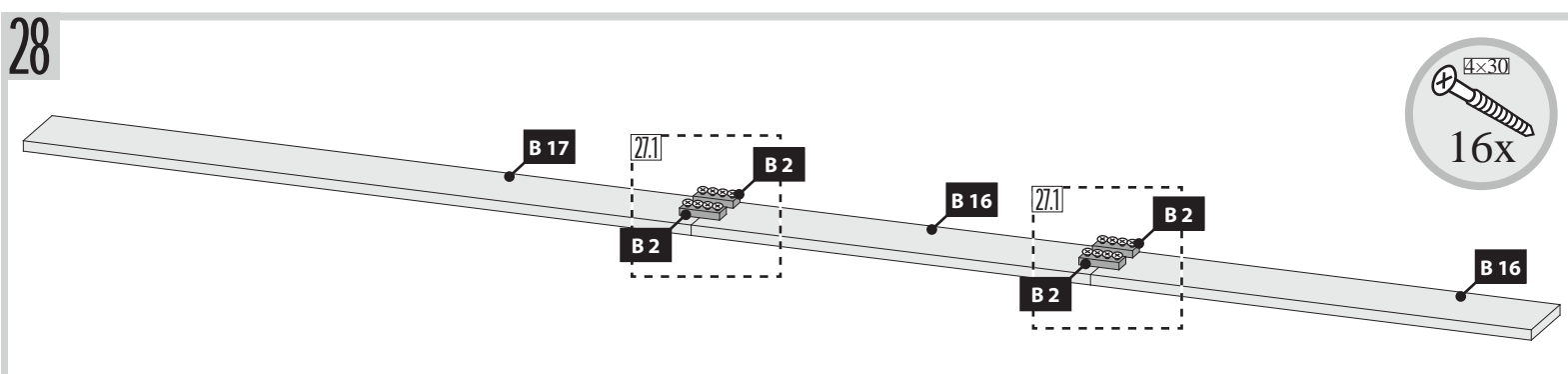
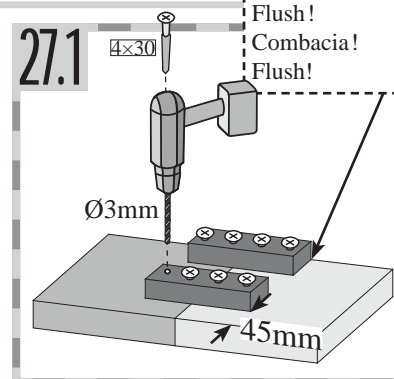
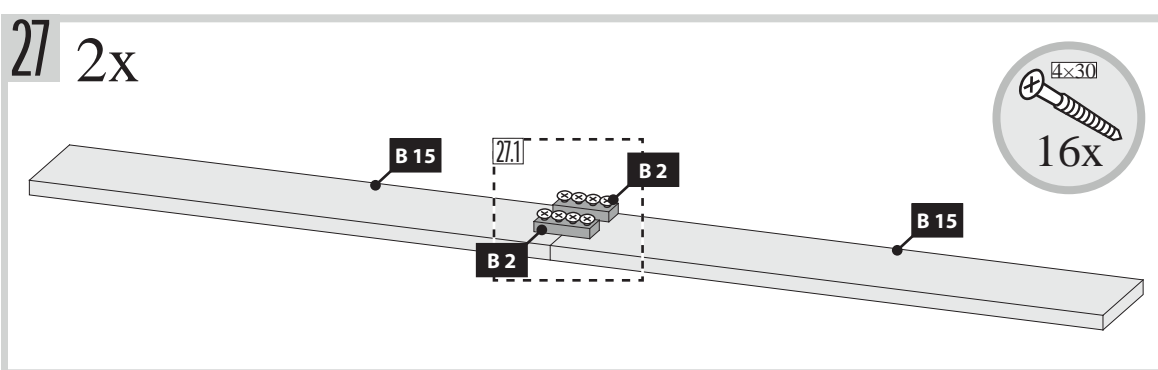
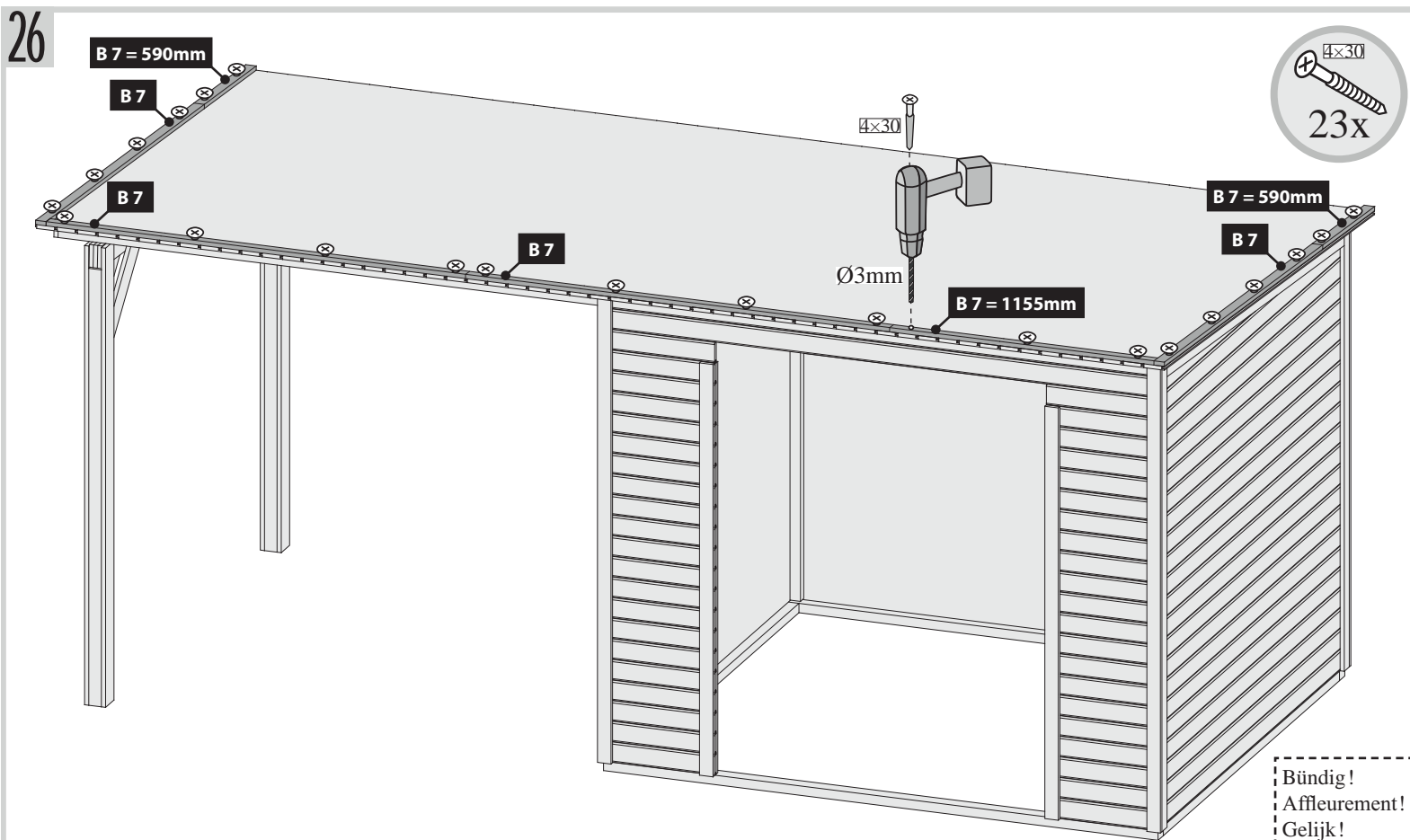
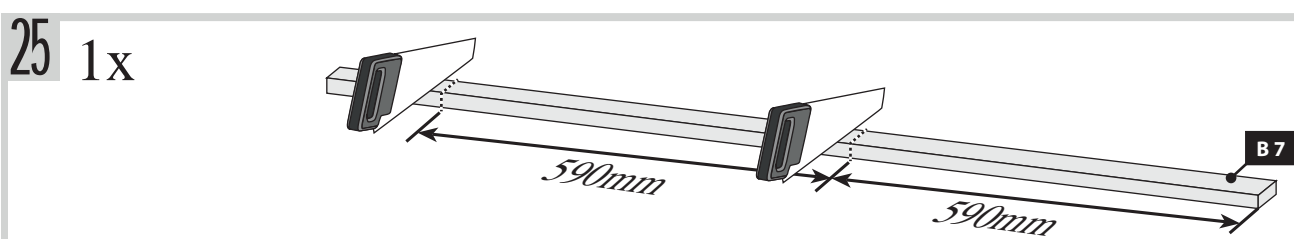
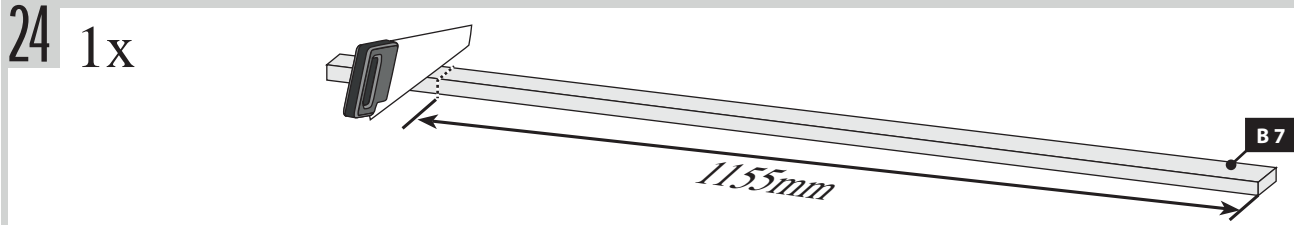

29

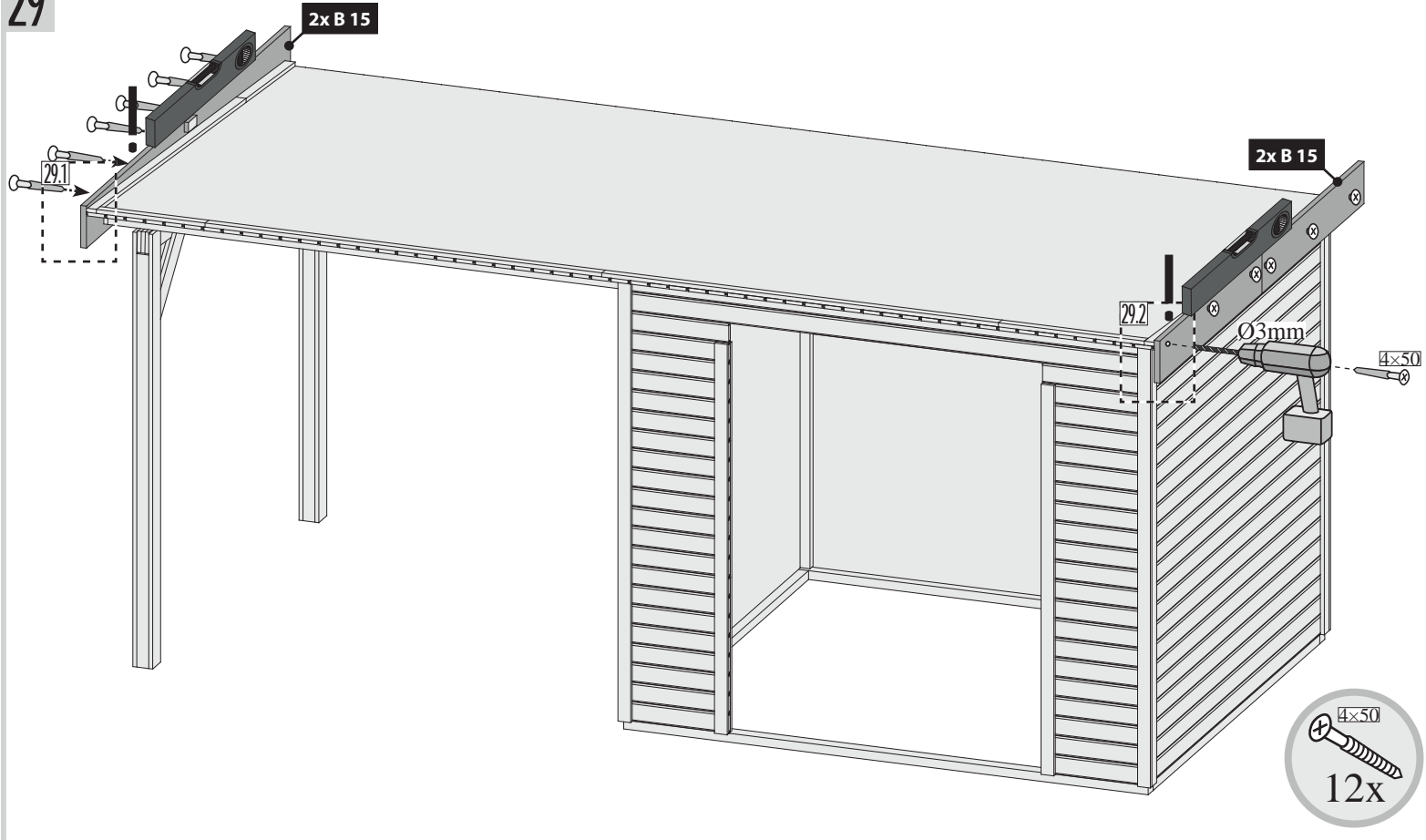

30

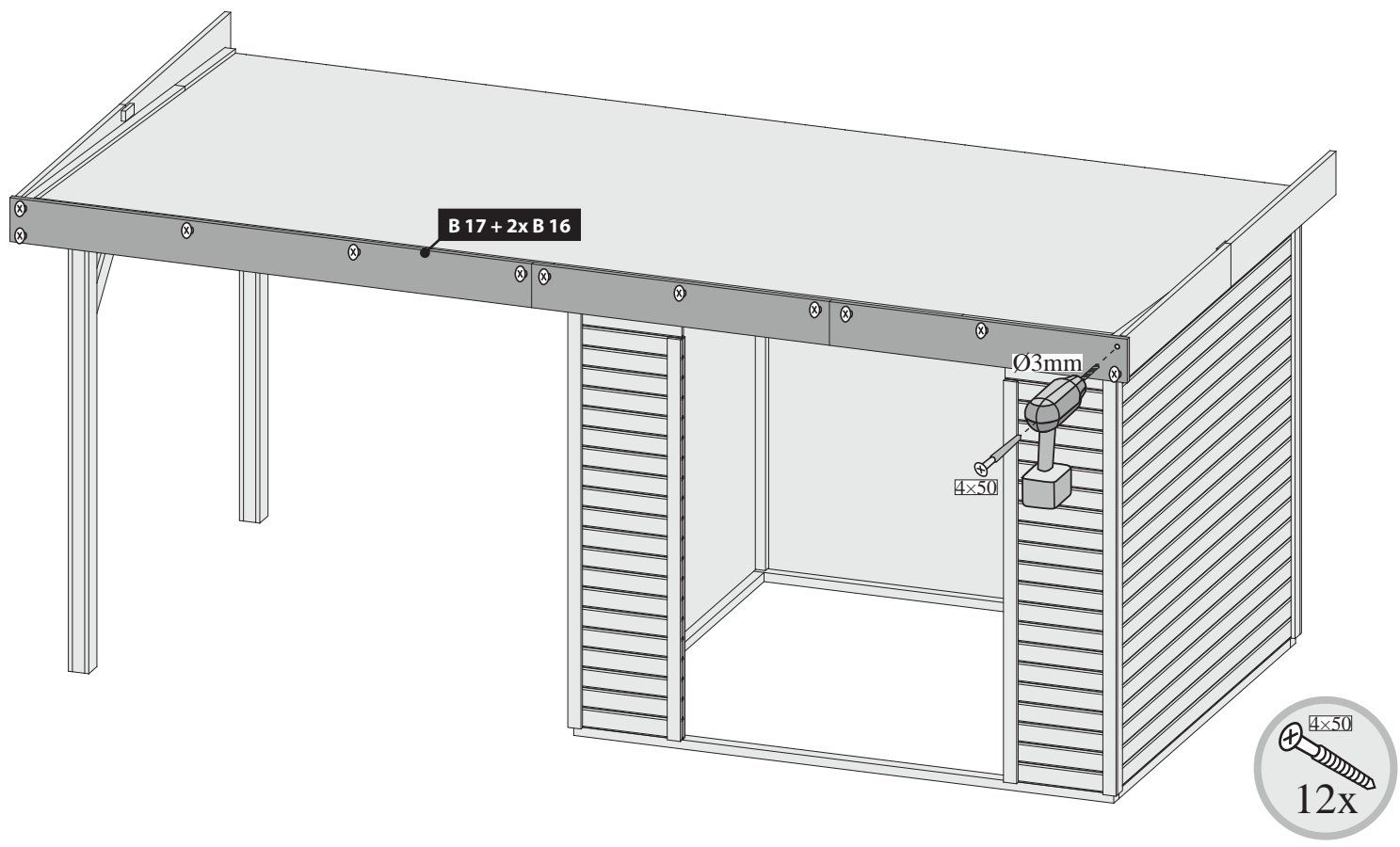

29.1

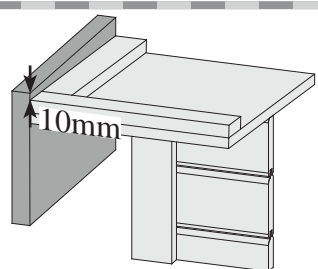

29.2

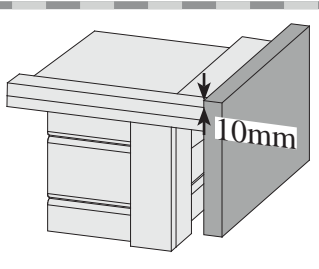

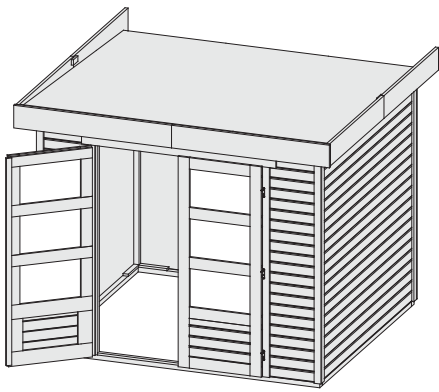

31A + 32A

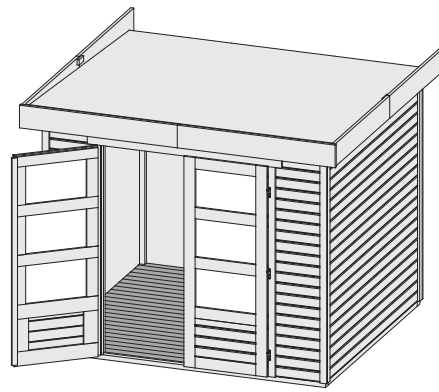

31B + 32B

31A

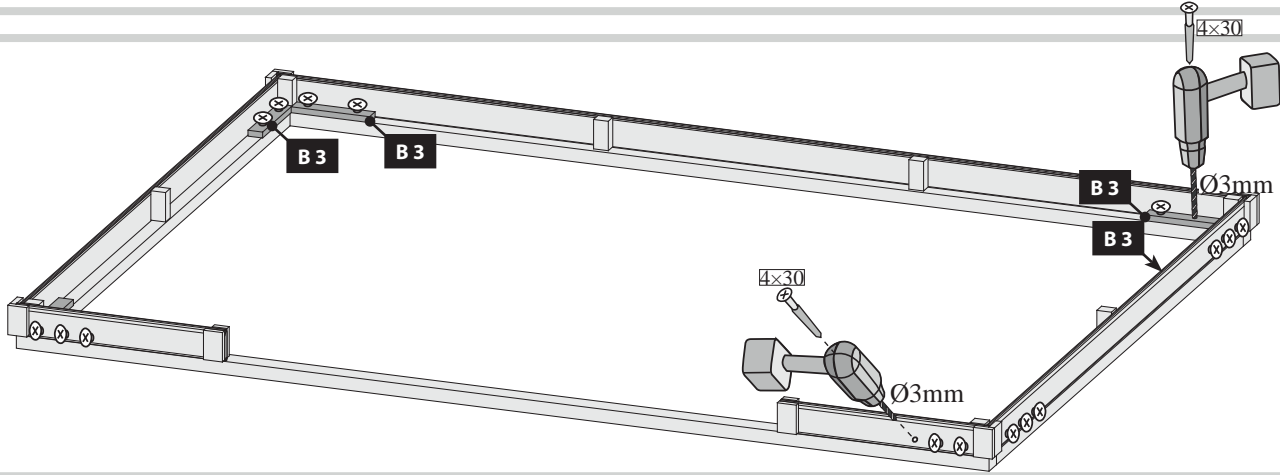

32A

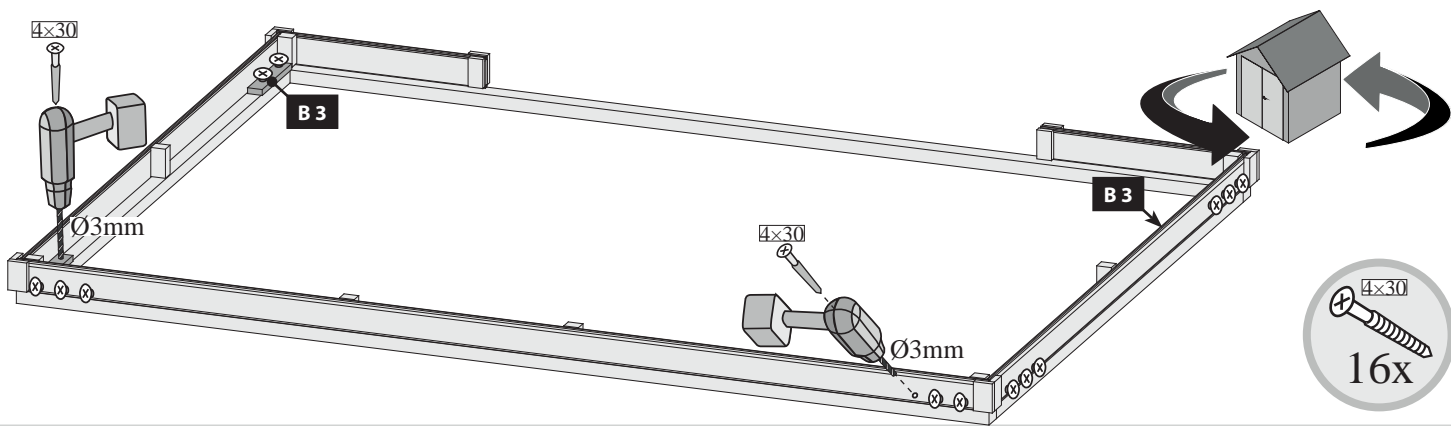

31B

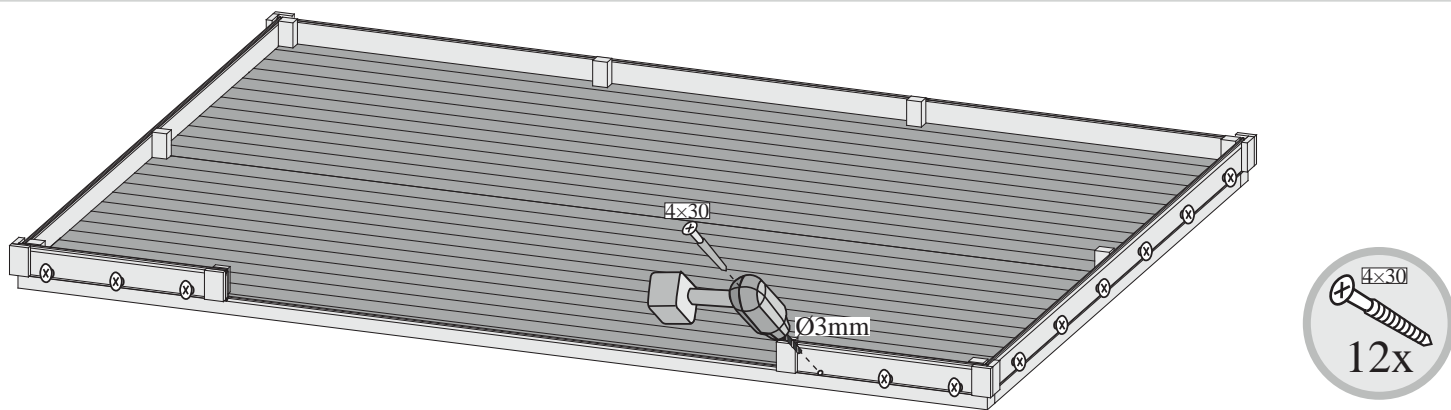

32B

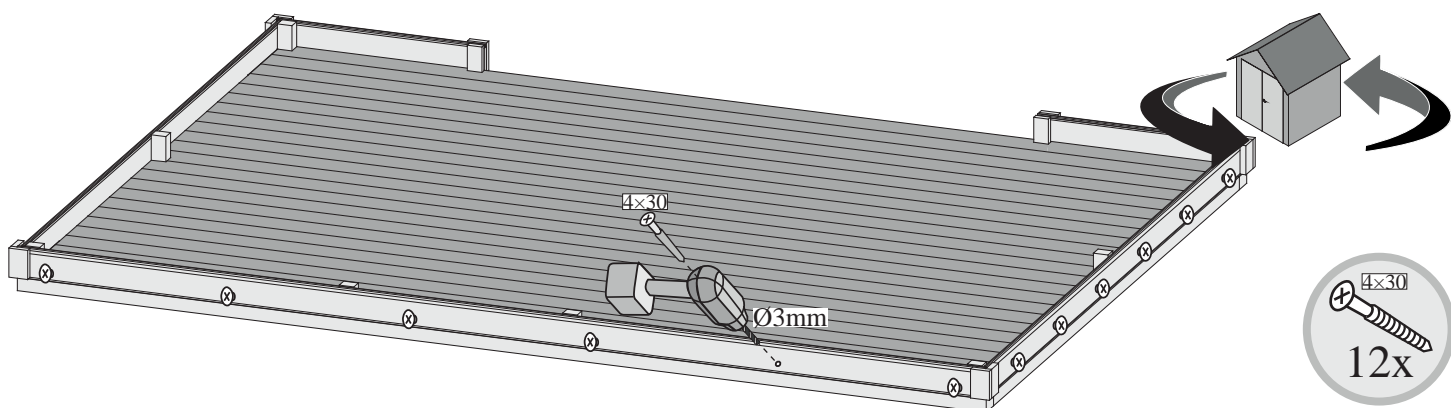



33

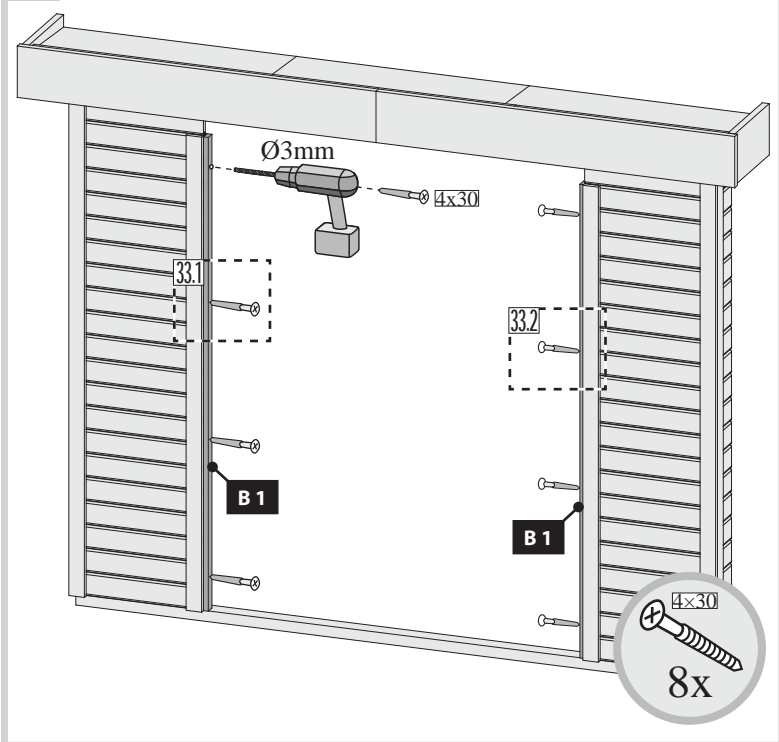

34

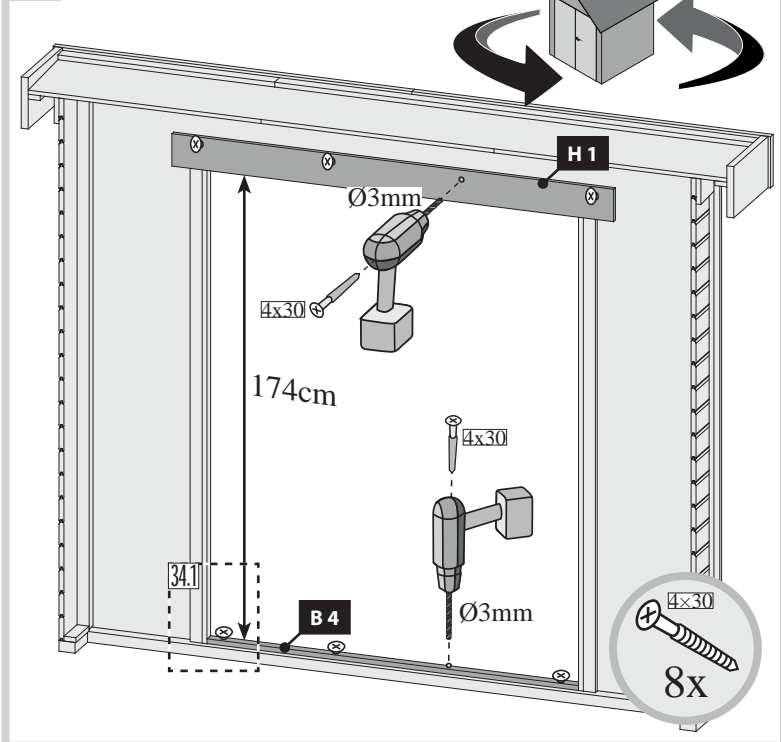

33.1

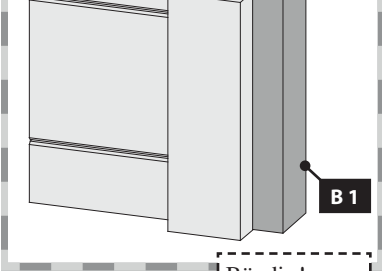

33.2

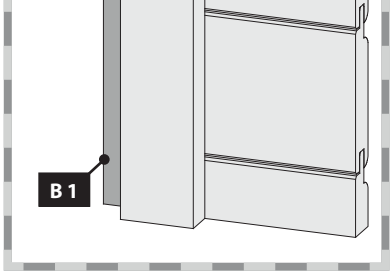

34.1

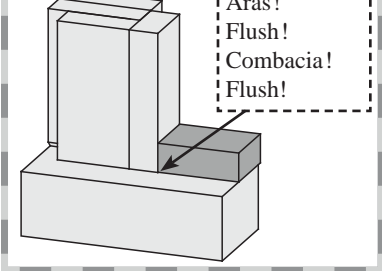

Bündig!  
Affleurement!  
Gelijk!  
Aras!  
Flush!  
Combacia!  
Flush!

35.1

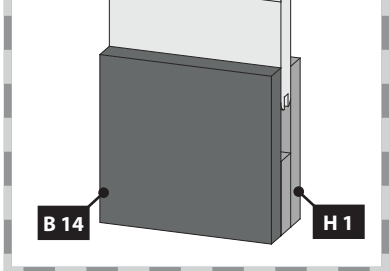

35

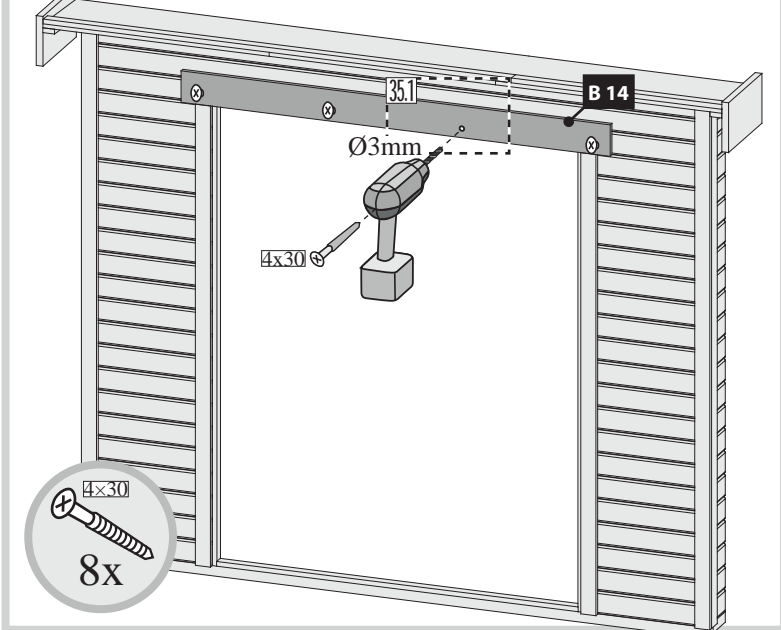

36

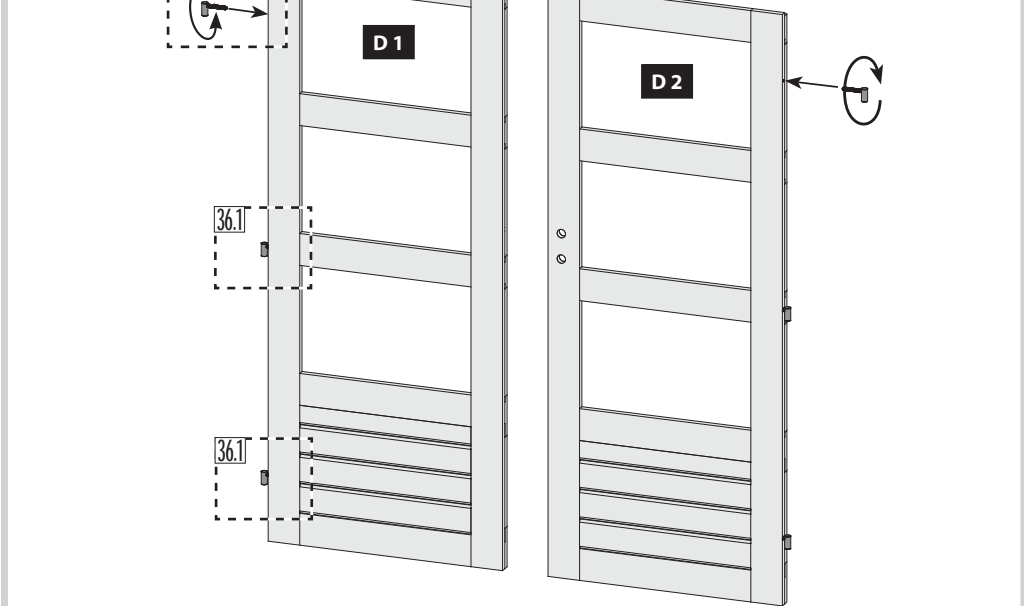

36.1-1

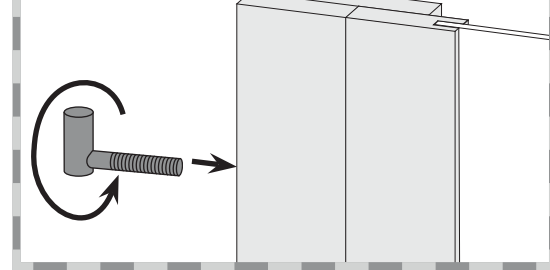

36.1-2

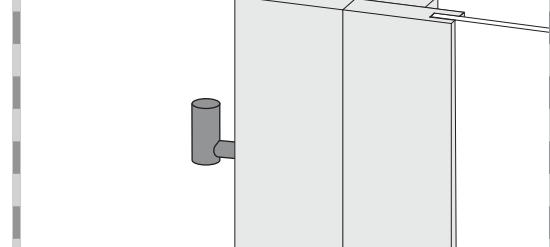

37

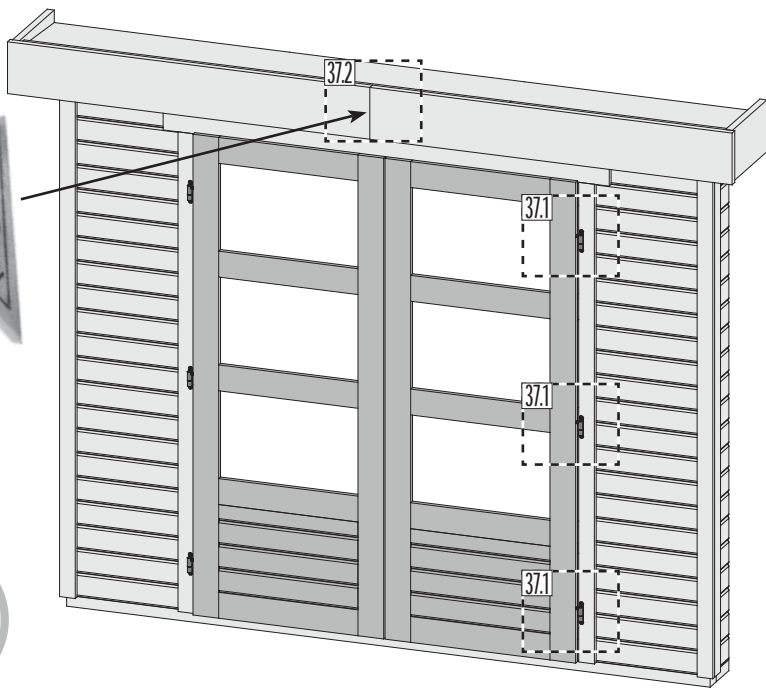

37.1-1

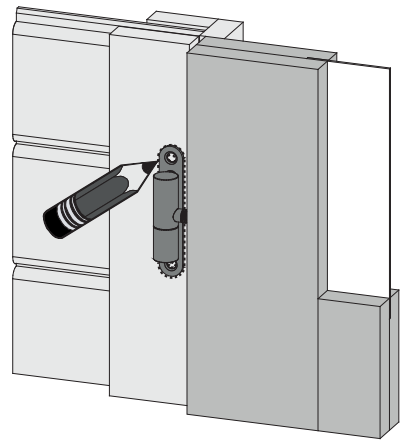

37.1-2

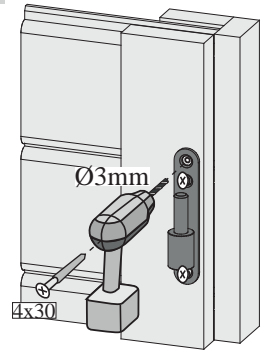

38

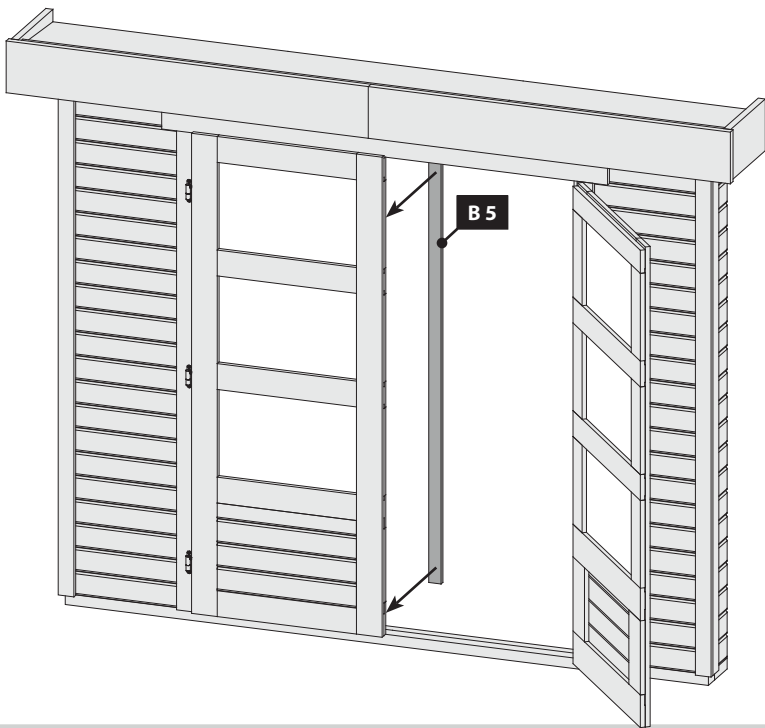

37.2

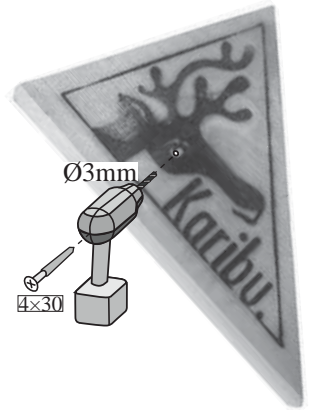

39

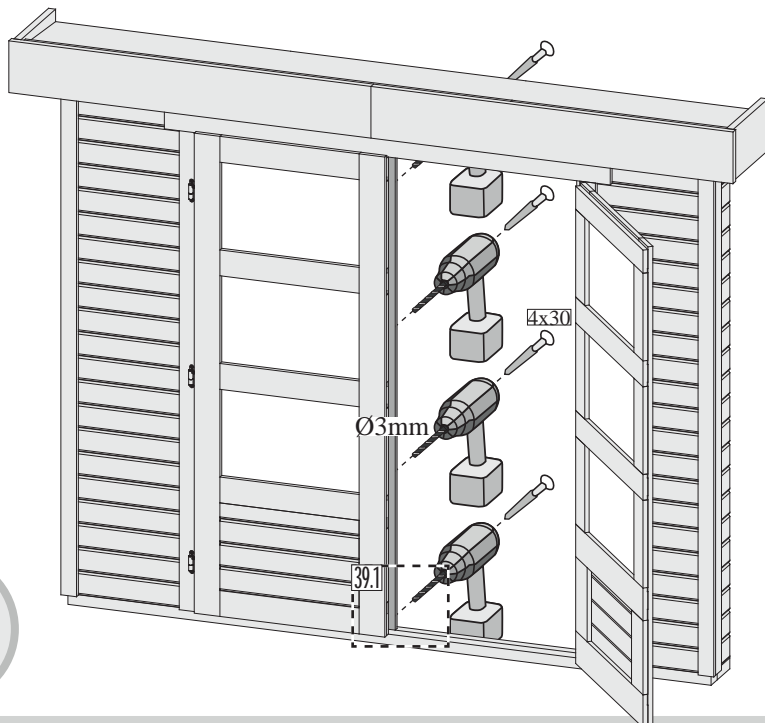

39.1

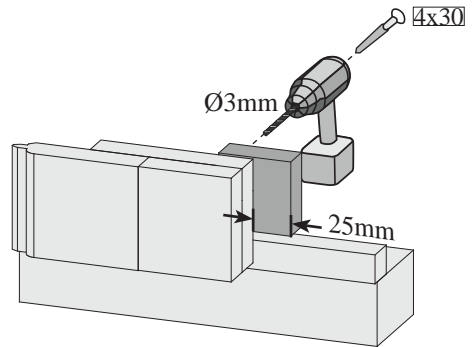

40

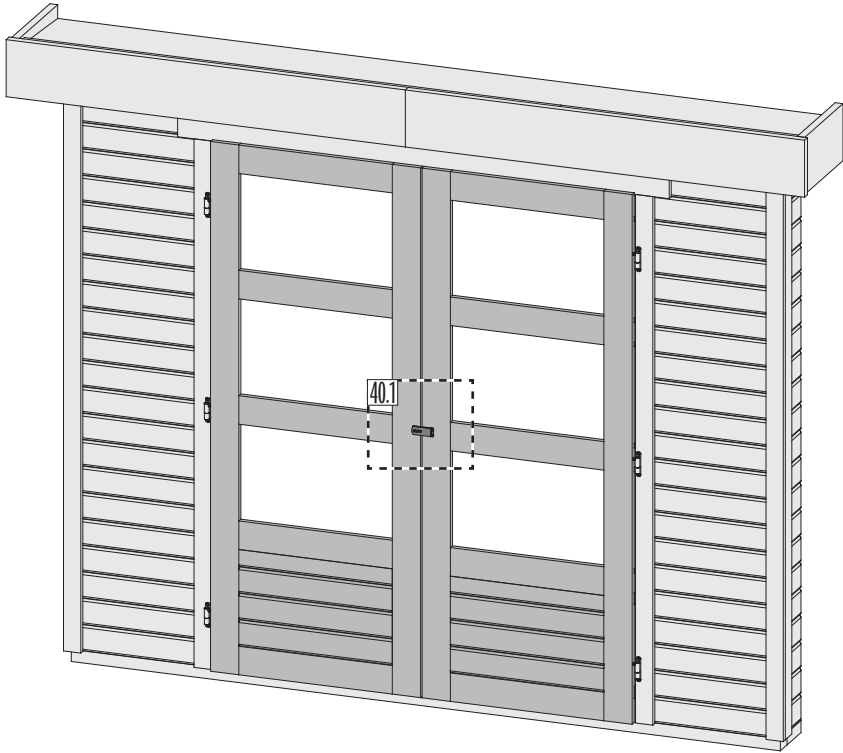

40.1-1

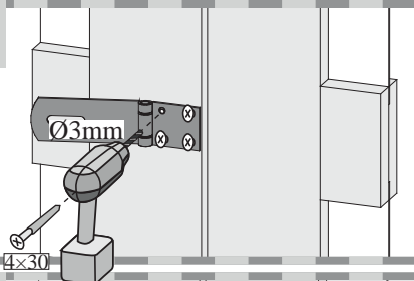

40.1-2

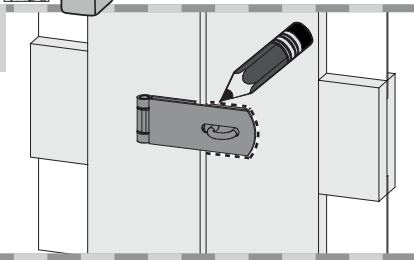

40.1-3

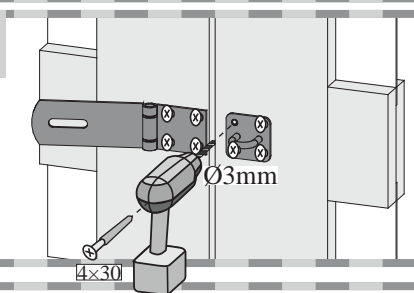

41.1-1

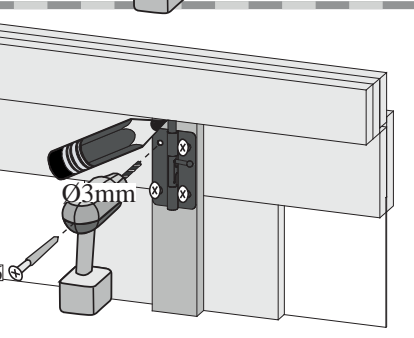

41.1-2

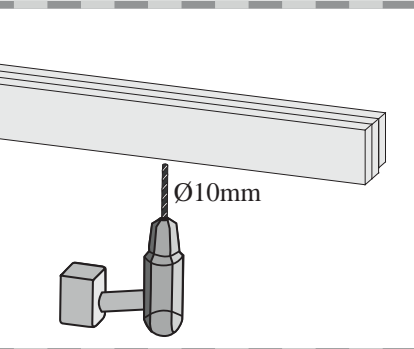

41.2-1

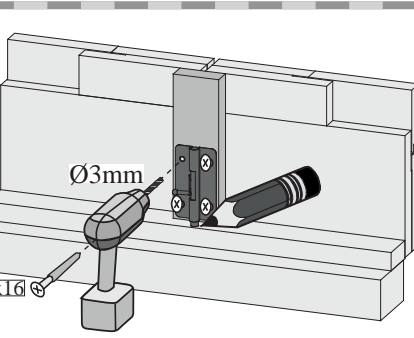

41.2-2

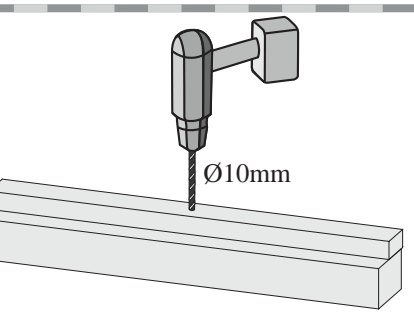

41

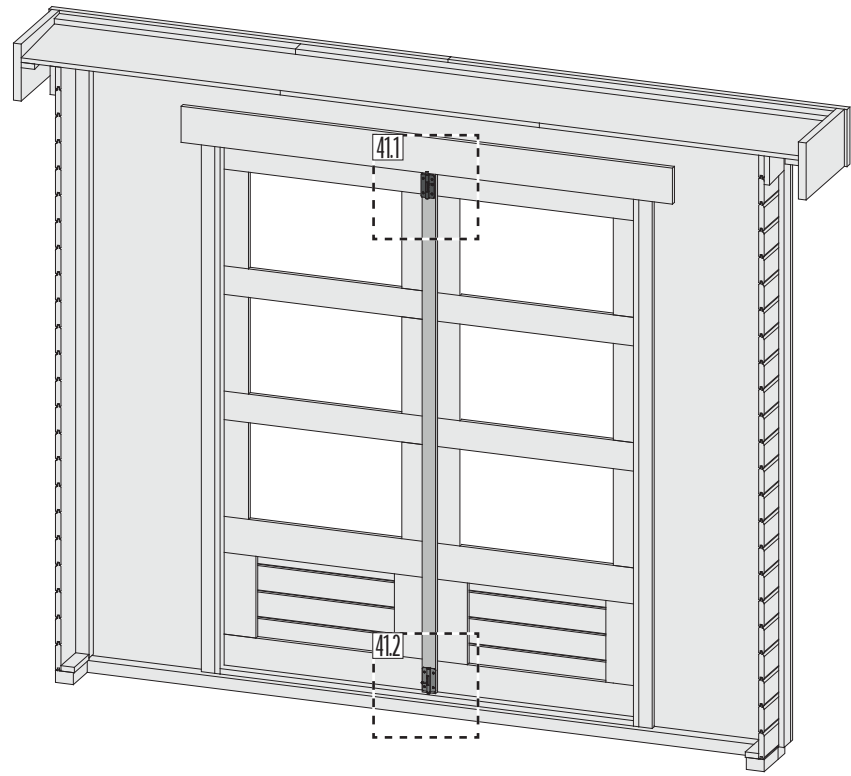
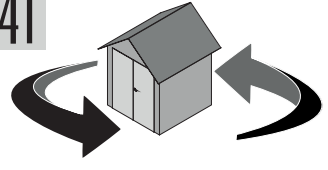

 Handling • Wartung • Pflege der Tür

 Handling • Maintenance • Care of the door

 Manejo • Mantenimiento • Cuidado de la puerta

 Usage • Maintenance • Entretien de la porte

 Handling • Onderhoud • Schoonmaken van de deur

 Installazione • Manutenzione • Cura del portoncino

### **Instandhaltung ist Voraussetzung für eine Gewährleistung**

Zur nachhaltigen Sicherung der Gebrauchstauglichkeit und Werthaltigkeit, ist auch während des Gewährleistungszeitraumes eine fachgerechte Wartung und Pflege erforderlich, die nicht in die Gewährleistungsverpflichtung eingeschlossen ist. Defekte müssen sofort nach der Entdeckung behoben werden.

### **Holzschutztechnische Behandlung der Tür**

Alle Bauteile der Tür müssen immer holzschutztechnisch behandelt werden. Die Stellen des Holzes, die später durch den Aufbau nicht mehr zugänglich sind sollten vor dem Aufbau vollständig behandelt werden.

Behandeln Sie das Produkt mit Bläuesperrgrund, anschließend versehen Sie es mit einem zweifachen Schutzanstrich einer offenporigen Holzschutzlasur. Spätestens alle zwei Jahre sollten Sie einen Schutzanstrich wiederholen.

Bei den Türen ist zu beachten, dass die eingesetzten Werkstoffplatten bei ungeeigneten Anstrichstoffen farbliche Abweichungen zu den Türen bekommen.

Bei farbigen und kesseldruckimprägnierten Häusern müssen lediglich die naturbelassenen Holzstellen (Sägeschnitte) und Teile nachbehandelt werden.

Eine gleichmäßige Farbdeckung ist im Innenbereich durch einmaliges Überstreichen zu erreichen. Verwenden Sie dazu einen offenporigen Wasserdispersionslack auf Acrylharzbasis.

Um eine hohe Lebensdauer Ihres Produktes zu gewährleisten sollten beschädigte Stellen sofort repariert werden. Dazu die beschädigte Stelle leicht anschleifen und erneut mit Farbe versehen. Erkundigen Sie sich nach geeigneten Lasuren bei Ihrem Farbenfachberater.

Weiterhin kann man, um eine hohe Lebensdauer der Tür zu gewährleisten und die Schlagregendichtigkeit zu erhöhen, den Holz-Fenster-scheibenübergang mit geeigneten Abdichtmassen versiegeln.

**Wurden diese Pflegemaßnahmen nicht sachgemäß durchgeführt, kann es zu Formänderungen, Bläue, Pilzbefall der Türen und Zargen und Verlust der Gewährleistung kommen.**

### **Reinigung**

Regelmäßige Reinigung und Pflege ist eine Grundvoraussetzung zur Erhaltung der Lebensdauer und Funktionsfähigkeit hochwertiger Produkte. Es sind Außen- und Innenseiten und auch der Falzbereich zu reinigen. Die Reinigungsmittel müssen dabei auf das entsprechende Material abgestimmt sein, was vor Beginn der Arbeiten zu prüfen ist.

### **Verformung der Tür**

Holz reagiert auf Umwelteinflüsse. So kommt es je nach Witterung zum Quellen und Schwinden des Holzes. Dadurch treten Maßabweichungen und leichte Verformungen auf.

Um die Schließfähigkeit der Tür zu erhalten, muss je nach Witterung die Tür durch Rein- und Rausdrehen an der Bänder ausgerichtet werden.

**Ein Verzug der Türen ist zu akzeptieren, solange die Funktion durch die hier aufgeführten Einstellmöglichkeiten gewährleistet ist.**

Für Schäden die durch Gewalteinwirkungen entstehen, besteht kein Gewährleistungsanspruch.

### **Einstellen der Tür**

Die Tür muss genau ausgerichtet werden damit eine einwandfreie Funktion gegeben ist. Der Türrahmen muss rechtwinklig und lotrecht eingebaut sein. Weiterhin muss der Türrahmen so montiert sein, dass er oben und unten die selbe Breite hat.

Schließt die Tür nicht, oder ein Türblatt hängt schief, kann dies durch leichtes Rein- oder Herausdrehen der Einschraubbänder berichtigt werden. Bis zu 5 Umdrehungen kann man diese Bänder rausdrehen. Wenn Sie eine Doppelflügeltür haben, muss der Feststellflügel stets nach oben und unten mittels der dafür vorgesehenen Beschlägen gesichert werden.

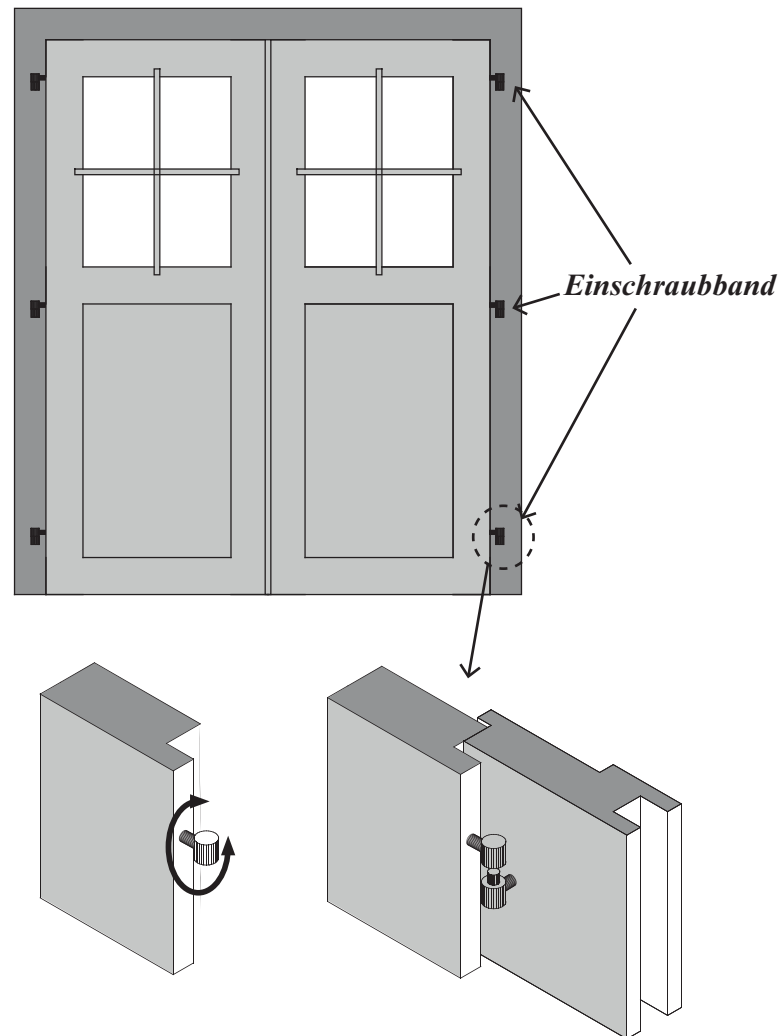

### **Beispiele für die Einstellung der Türen:**

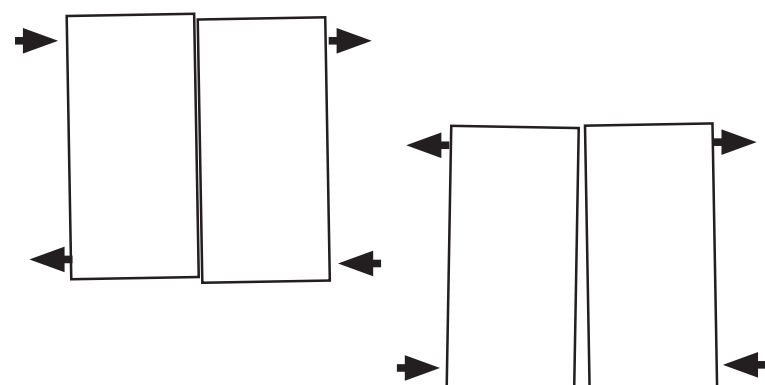

 Handling • Wartung • Pflege  
der Tür

 Handling • Maintenance • Care  
of the door

 Manejo • Mantenimiento •  
Cuidado de la puerta

 Usage • Maintenance •  
Entretien de la porte

 Handling • Onderhoud •  
Schoonmaken van de deur

 Installazione • Manutenzione •  
Cura del portoncino

### ***La garantie liée au matériel est subordonnée à son entretien.***

Afin d'assurer au matériel un fonctionnement et une valeur durables, une maintenance et un entretien appropriés pendant toute la durée de la garantie sont nécessaires mais ne font pas partie intégrale de la garantie. Il convient de remédier aux anomalies ou aux défauts aussitôt après leur constatation.

### ***Technique de traitement pour la préservation du bois***

Les éléments de la porte au complet font l'objet d'une technique de traitement de préservation du bois. Après le montage, certaines parties du bois ne seront plus accessibles. Elles seront par conséquent traitées entièrement avant le montage.

Apposer avec une couche d'anti-corrosif sur le bois puis passer deux couches de lasure à pores ouverts pour bois. Repasser une couche de lasure de protection au moins tous les deux ans.

Noter qu'une peinture non appropriée pour les panneaux en contreplaqué peut donner ultérieurement une couleur différente de celle des portes.

En ce qui concerne les maisonnettes prépeintes et autoclavées, seuls les emplacements où le bois brut apparaît, tels que les parties sciées et les divers éléments, doivent subir un traitement complet.

Il suffit de passer une seule couche sur la surface intérieure pour obtenir une couleur homogène.

Pour ce faire, il est conseillé d'utiliser une laque à dispersion aqueuse et à pores ouverts à base de résine acrylique.

Afin d'assurer au produit une longévité maximum, il est recommandé de réparer immédiatement les parties endommagées qui seront légèrement poncées dans un premier temps puis enduites d'une nouvelle couche de peinture. Renseignez-vous sur les lasures appropriées auprès de votre magasin de peintures.

Pour obtenir une longévité maximum de la porte et une optimisation de son imperméabilité contre les intempéries, colmater les espaces entre l'encadrement et la vitre de la fenêtre avec un mastic ou une pâte de colmatage adaptés.

***Ces mesures d'entretien, si elles ne sont pas appliquées de manière appropriée, peuvent provoquer des déformations, des attaques de corrosion, des attaques fongiques des portes et des encadrements et entraînent la perte de la garantie liée au produit.***

### ***Nettoyage***

Un nettoyage et un entretien réguliers garantissent une longévité maximum et un excellent fonctionnement des produits de haute qualité. Nettoyer les parois extérieures et intérieures ainsi que les jointures.

Les produits de nettoyage doivent être appropriés au matériel à traiter. Vérifier leur compatibilité avant le commencement des travaux.

### ***Déformation de la porte***

Le bois réagit sous l'influence de son environnement. C'est ainsi qu'il gonfle et qu'il se resserre selon le temps qu'il fait. Il peut en résulter des variations de proportions et des déformations.

C'est pourquoi, afin d'obtenir la fermeture exacte d'une porte, il est nécessaire de procéder à un ajustement de la fixation au cours des changements de saison en enfonçant les fiches vers l'intérieur ou en les dévissant vers l'extérieur.

***Une déformation des portes est acceptable dans la mesure où son fonctionnement est assuré par les diverses possibilités de réglage décrites ici.***

Aucun droit de garantie ne sera reconnu en cas de dégâts provenant de manipulations violentes.

### ***Réglage de la porte***

Pour obtenir un fonctionnement parfait, la porte doit être assemblée avec précision. L'encadrement doit être assemblé à angle droit et à la verticale. Il doit également présenter la même largeur dans sa partie supérieure et dans sa partie inférieure.

Si une porte ne ferme pas ou si un battant est de travers, enfoncer les fiches à visser ou les dévisser légèrement vers l'extérieur (5 rotations sont possibles). Dans le cas d'une porte à deux battants, le battant de verrouillage doit toujours être fixé en haut et en bas avec les ferrures prévues à cet effet.

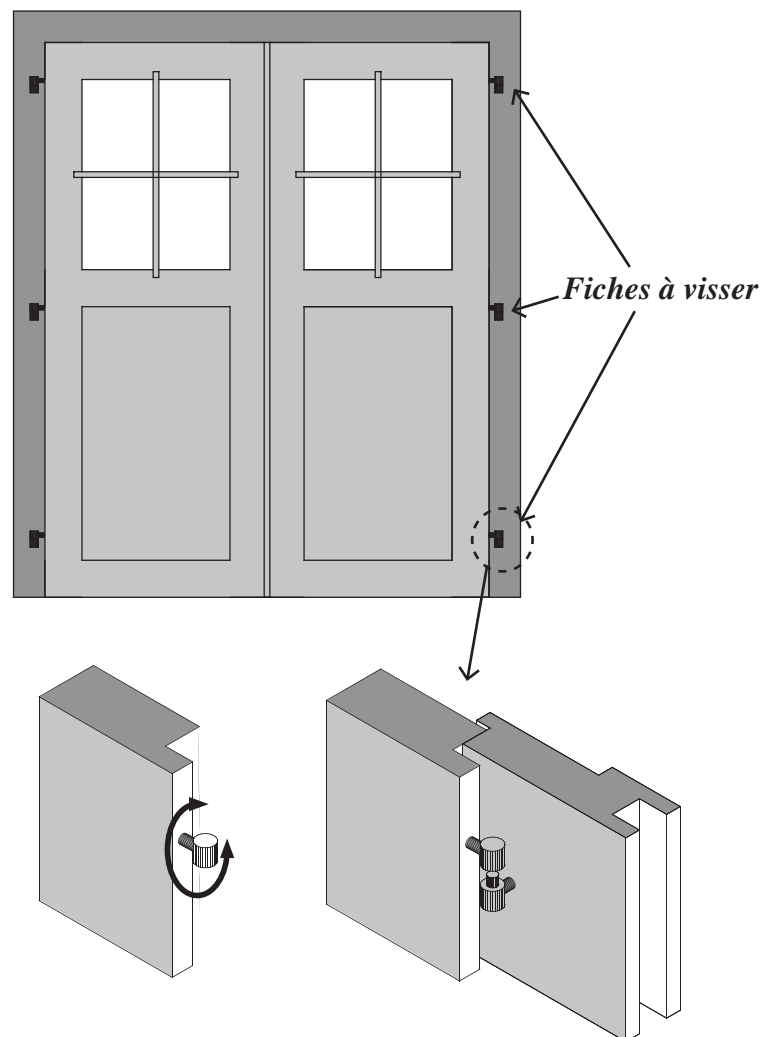

### ***Exemples de réglage des portes:***

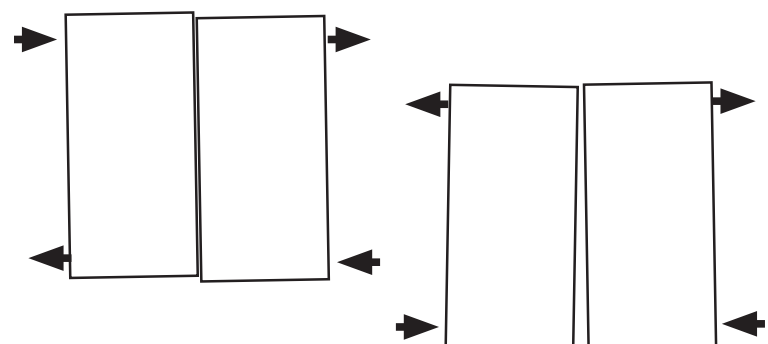

 Handling • Wartung • Pflege  
der Tür

 Handling • Maintenance • Care  
of the door

 Manejo • Mantenimiento •  
Cuidado de la puerta

 Usage • Maintenance •  
Entretien de la porte

 Handling • Onderhoud •  
Schoonmaken van de deur

 Installazione • Manutenzione •  
Cura del portoncino

### ***The guarantee is conditional on proper upkeep!***

For lasting protection of the value and suitability for use, professional care and maintenance is also recommended during the warranty period; this is not included in the warranty obligations. Defects must be repaired immediately upon detection.

### ***Wood protection treatment of the door***

All parts of the door must receive wood protection treatment. Those sections of the wood, which will not be accessible after installation, should receive complete treatment before installation.

Treat the product with a blue stain blocking coat; afterwards apply a double protective coating of an open-pored wood-protection glaze. Application of a protective coating should be repeated at least every two years.

Please beware that the inserted plates of other material may come to differ in colour to the doors if you use unsuitable coating material.

With coloured and boiler pressure impregnated houses, only the exposed natural wood (saw cuts) and parts should need extra treatment.

You can obtain an even colour covering in inside areas with one coat of paint.

For that you should use an open-pored, acrylic based water dispersed lacquer.

In order to guarantee a long service life of your product you should repair damaged areas immediately. Do this by whetting the damaged area and apply a new coat of paint.

Enquire about suitable glazes at your local paint retailer.

Furthermore, you can seal the joining of the wood-window pane with a suitable sealant to guarantee a long service life of the door and prevent leakage from heavy rain.

***If these precautions of care are not properly carried out, it can result in deformation, blue stain, fungus infestation in the doors and frames and loss of warranty.***

### ***Cleaning***

Regular cleaning and care is a prerequisite for preserving the service life and functionality of high-value products. Cleaning is to take place outside, inside and also in the rabbet-area.

The cleaning agent used must be suitable for the relevant material; please do a test before you start cleaning.

### ***Deformation of the door***

Wood reacts to environmental influences. Weather exposure will lead to swelling and contraction of the wood. This causes variances of dimensions and slight deformation.

Dependant on the weather exposure, the door may need realignment by turning the hinges in- or outwards.

***Some door warpage is acceptable as long as the door can be made to function through the alignment options specified here.***

The warranty does not cover damage caused by use of excessive force.

### ***Adjustment of the door***

The door must be accurately adjusted to ensure trouble-free operation. The door frames must be installed right-angled and perpendicular. Furthermore, they must be installed so the width of the frame is the same at the top and bottom.

If the door doesn't close or if one panel is askew, this can be rectified by limited in- or outwards turning of the hinges. You can turn the hinges outwards up to 5 rotations. If you have a double-door, the door to be secured must always be correctly aligned at the top and bottom with the appropriate hinges.

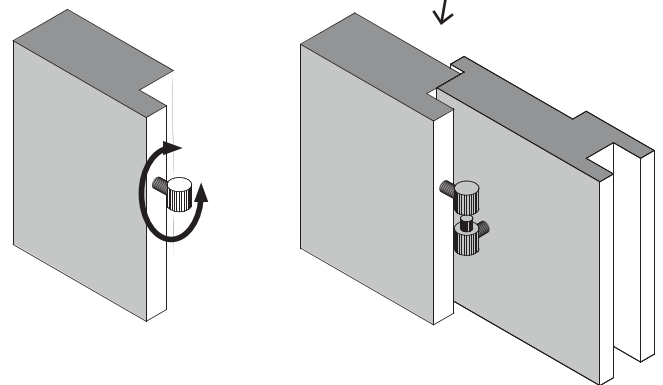
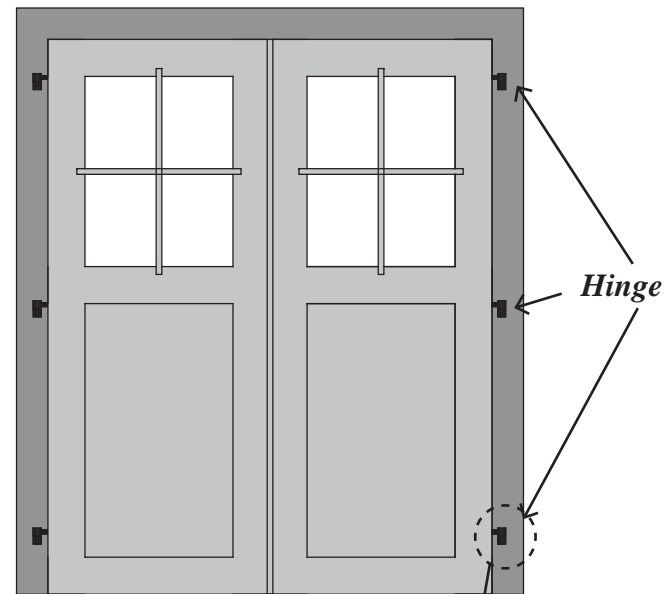

### ***Examples of the adjustment of the doors:***

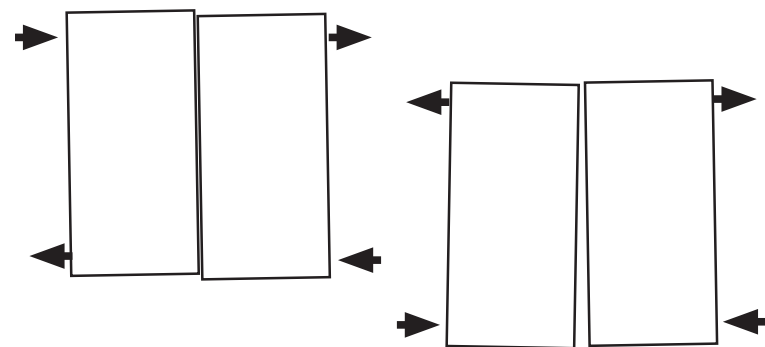

 Handling • Wartung • Pflege der Tür

 Handling • Maintenance • Care of the door

 Manejo • Mantenimiento • Cuidado de la puerta

 Usage • Maintenance • Entretien de la porte

 Handling • Onderhoud • Schoonmaken van de deur

 Installazione • Manutenzione • Cura del portoncino

### **Onderhoud is een voorwaarde voor garantie!**

Om de bruikbaarheid en waardevastheid duurzaam te waarborgen, is ook tijdens de garantieperiode deskundig onderhoud noodzakelijk; dit maakt geen deel uit van de garantieverplichting. Defecten moeten onmiddellijk na ontdekking ervan worden verholpen.

### **Houtbeschermingstechnische behandeling van de deur**

Alle onderdelen van de deur moeten altijd houtbeschermingstechnisch worden behandeld. De plaatsen van het hout die later als het huisje is gemonteerd niet meer toegankelijk zijn, dient u vóór het opbouwen volledig te behandelen.

Behandel de deur vóór het opbouwen met antiblauwmiddel, daarna voorzien van een dubbele beschermende coating van ademende houtbeschermende beits. Uiterlijk om de twee jaar dient u de deklaag over te schilderen.

Bij de deurtjes moet in acht worden genomen dat de gebruikte platen materiaal in geval van ongeschikte soorten verf kleurafwijkingen t.o.v. de rest van de deurtjes krijgen.

Bij geleverde en onder vacuümdruk geïmpregneerde huisjes hoeven alleen de naturel houten onderdelen (zaagkant) en houtdelen te worden nabehandeld.

Een gelijkmatig dekkende kleur kan binnen door één keer overschilderen worden verkregen. Gebruik daarvoor een ademende watergedragen dispersielak op acrylharsbasis.

Om een lange levensduur van uw product te garanderen, dienen beschadigde plaatsen onmiddellijk te worden gerepareerd. Daarvoor de beschadigde plaats licht opschuren en van een nieuwe verflaag voorzien.

Informeer naar geschikte beitsen bij uw verfspecialzaak.

Verder kunt u, om een lange levensduur van de deur te waarborgen en de slagregendichtheid te verbeteren, de overgang tussen het hout en de ruiten met een geschikte kit afdichten.

**Als deze onderhoudsmaatregelen niet oordeelkundig worden uitgevoerd, bestaat het risico van vormveranderingen, blauwheid, schimmelaantasting van de deuren en kozijnen en daarmee verlies van de garantie.**

### **Schoonmaken**

Regelmatig schoonmaken en onderhoud is een basisvoorwaarde voor het behoud van de levensduur en de goede werking van hoogwaardige producten. Binnen en buitenkanten alsmede de sponning moeten goed worden schoongehouden.

Daarbij moeten de schoonmaakmiddelen zijn afgestemd op het betreffende materiaal, hetgeen vóór het begin van de werkzaamheden dient te worden gecontroleerd.

### **Vervorming van de deur**

hout reageert op omgevingsinvloeden. Zo zal het hout afhankelijk van de weersomstandigheden opzwellen en krimpen. Daardoor treden er maatafwijkingen en lichte vervormingen op.

Om ervoor te zorgen dat de deur goed blijft sluiten, moet afhankelijk van de weersgesteldheid de deur door in- en uitschroeven van de scharnieren worden afgesteld.

**Iets scheefftrekken van de deuren moet worden geaccepteerd zolang de werking door de hier genoemde instelmogelijkheden is gewaarborgd.**

Voor schade die ontstaat door het toepassen van geweld bestaat geen aanspraak op garantie.

### **Instellen van de deur**

De deur moet nauwkeurig worden afgesteld om goed te kunnen werken. Het deurkozijn moet haaks en loodrecht zijn gemonteerd. Verder moet het frame zo zijn gemonteerd dat het boven en onder even breed is.

Als de deur niet sluit of een deurblad hangt scheef, dan kan dit worden gecorrigeerd door de schroefscharnieren iets naar binnen of naar buiten te draaien. Deze scharnieren kunnen max. 5 slagen naar buiten worden gedraaid. Als u een dubbele openslaande deur heeft, moet het vaste gedeelte steeds naar boven toe en met behulp van het daarvoor bedoelde sluitwerk worden vastgezet.

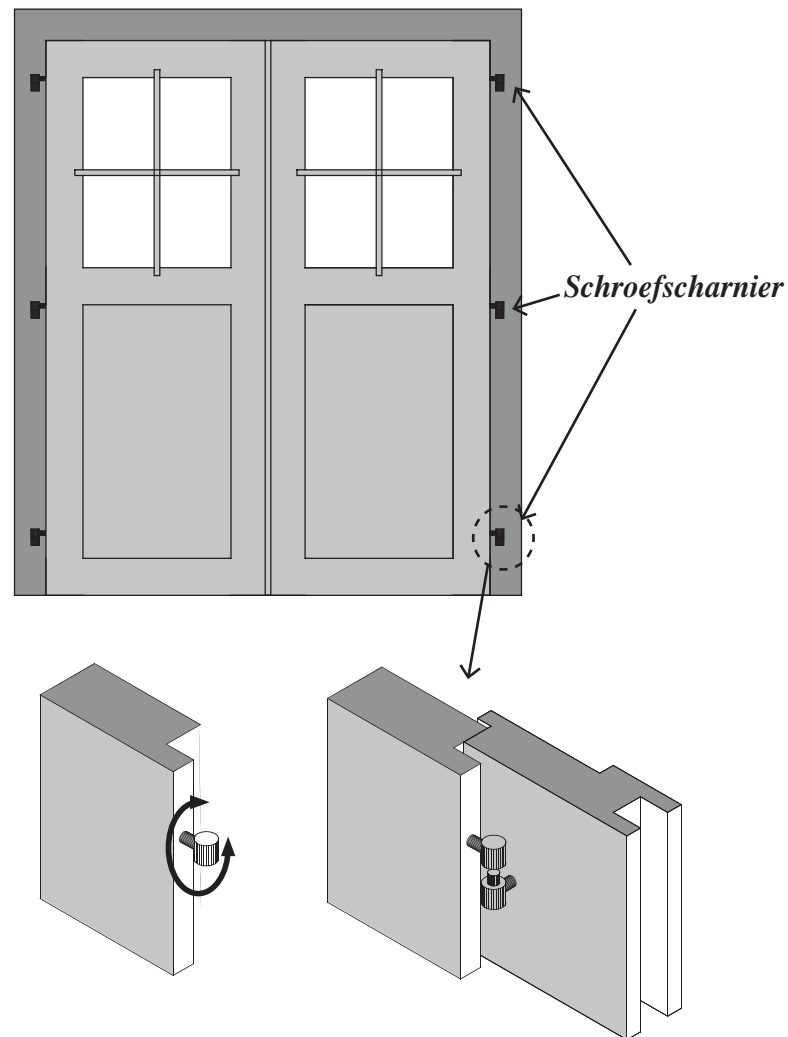

### **Voorbeelden voor het instellen van de deuren:**

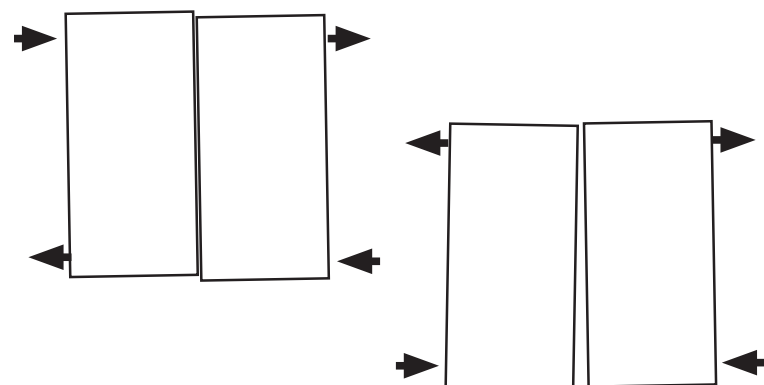

 Handling • Wartung • Pflege der Tür

 Handling • Maintenance • Care of the door

 Manejo • Mantenimiento • Cuidado de la puerta

 Usage • Maintenance • Entretien de la porte

 Handling • Onderhoud • Schoonmaken van de deur

 Installazione • Manutenzione • Cura del portoncino

### ***¡Para cualquier garantía es condición previa que se realice la conservación!***

Para asegurar de forma duradera la utilidad y el valor también es necesario que se realice durante el periodo de validez de la garantía el mantenimiento y cuidado apropiados, que no están incluidos en las obligaciones de la garantía. Los defectos deberán ser reparados inmediatamente después de detectarse.

### ***Tratamiento técnico protector de madera de la puerta***

Todas las piezas constructivas de la puerta deberán tratarse siempre según la técnica para protección de madera. Aquellas partes o zonas de la madera que, tras el montaje, ya no serán accesibles deberán ser tratadas completamente antes de proceder a su montaje.

Trate usted el producto con una imprimación protectora contra el hongo de azuleo, a continuación aplíquelo dos manos de barniz protector de madera de poros abiertos. Como muy tarde cada dos años se debería aplicar de nuevo una mano de protección.

En las puertas deberá tenerse en cuenta que las planchas utilizadas pueden presentar variaciones de color, si no se utilizan los materiales de pintura apropiados.

En casas de colores e impregnadas por medio de caldera a presión solamente se deberán tratar posteriormente las zonas (cortes serrados) y piezas o partes de madera que se hayan dejado al natural.

En el interior se deberá conseguir una cubrición de pintura homogénea mediante la aplicación de una sola mano.

A fin de garantizar una larga duración de vida útil de su producto las zonas o partes dañadas se deberán reparar de inmediato. Para ello se lijarán un poco las zonas dañadas y se volverá a aplicar pintura. Infórmese sobre los barnices apropiados en su asesor técnico de colores. Para garantizar una larga duración de vida útil de la puerta y para aumentar la impermeabilidad a la lluvia que viene de lado por el viento se deberán sellar las transiciones entre la madera y el vidrio de la ventana con alguna masilla selladora adecuada.

***Si no se han llevado a cabo correctamente estas medidas de conservación y cuidado, podrán producirse deformaciones, hongos de azuleo y hongos en general en las puertas, bordes y cercos, con lo que se puede extinguir la garantía.***

### ***Limpieza***

La limpieza y el cuidado periódicos son condición previa básica para mantener la vida útil y la funcionalidad de los productos de alta calidad. También se deberán limpiar las partes interiores y exteriores en la zona de los encajes y las ensambladuras. Los detergentes o agentes limpiadores deberán ser apropiados para cada material en cuestión. Se deberá comprobar la idoneidad de dichos agentes antes de comenzar el trabajo.

### ***Deformación de la puerta***

La madera reacciona a las influencias del medio ambiente. Así, según el clima que haga, pueden producirse hinchamientos y encogimientos de la madera. Debido a este fenómeno se producen variaciones o desviaciones de las medidas y dimensiones y, por tanto, ligeras deformaciones. Para mantener la capacidad de cierre de la puerta se adaptará la misma, según las condiciones climáticas y sus repercusiones, girando hacia fuera o hacia adentro los pernios.

***Se podrá aceptar una deformación de la puerta, siempre que su funcionamiento siga garantizado mediante las posibilidades de ajuste indicadas en las presentes instrucciones.***

No se asumirá garantía alguna por aquellos daños que hayan sido causados por acción violenta.

### ***Ajustar la puerta***

La puerta deberá estar exactamente alineada a fin de que su funcionamiento perfecto esté garantizado. El marco de la puerta deberá estar montado en ángulo recto y perpendicularmente. Asimismo el marco de la puerta deberá estar montado de manera que tenga el mismo ancho arriba que abajo.

Si la puerta no cierra o una hoja de la misma está torcida, se podrá corregir roscando o desenroscando un poco los pernios. Estos pernios se pueden desenroscar hasta 5 vueltas. Si tiene usted una puerta de dos hojas, la hoja de retención siempre se deberá fijar tanto arriba como abajo con los herrajes correspondientes previstos para dicho fin.

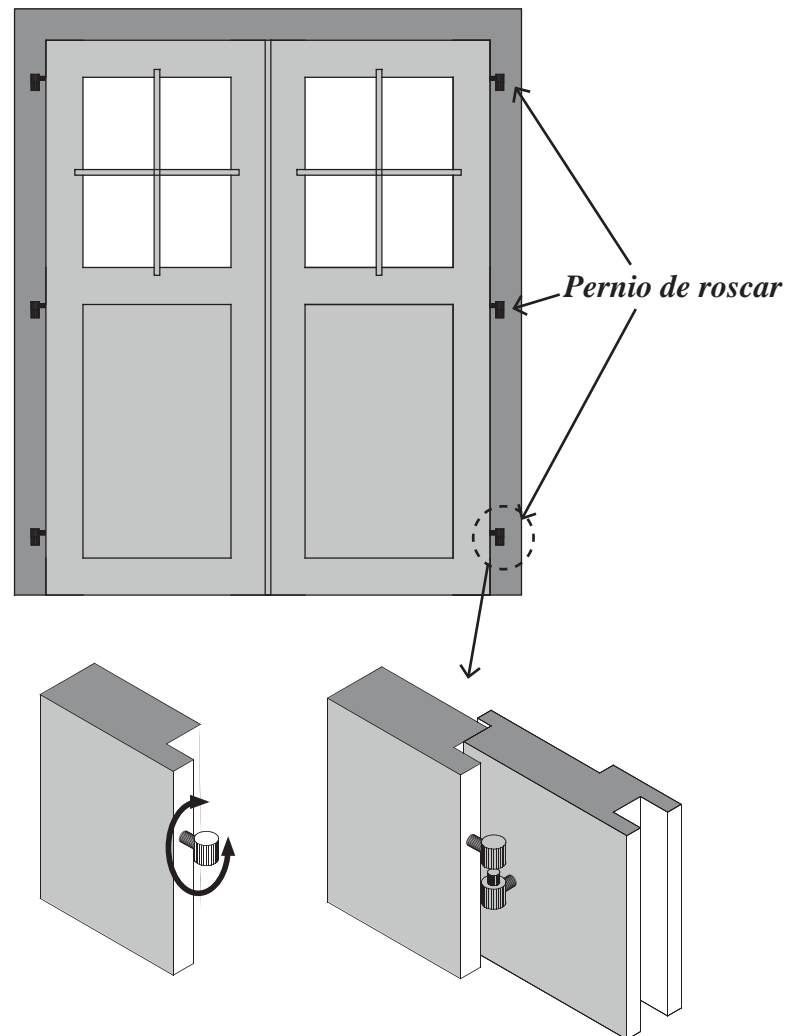

### ***Ejemplos para ajustar las puerta:***

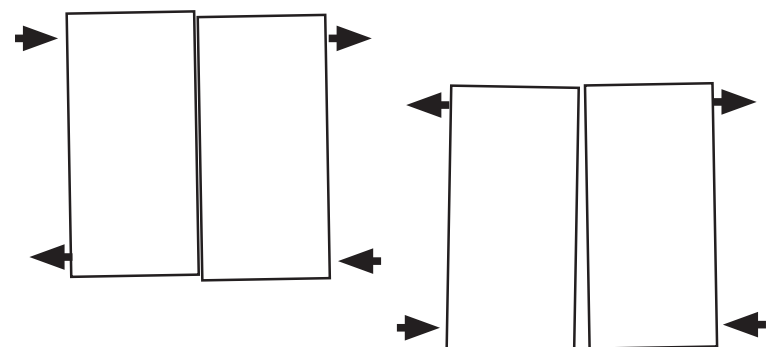



 Handling • Wartung • Pflege  
der Tür

 Handling • Maintenance • Care  
of the door

 Manejo • Mantenimiento •  
Cuidado de la puerta

 Usage • Maintenance •  
Entretien de la porte

 Handling • Onderhoud •  
Schoonmaken van de deur

 Installazione • Manutenzione •  
Cura del portoncino

### ***Una corretta manutenzione è la premessa per il ricorso alla garanzia.***

Per garantire l'idoneità all'uso del portoncino e mantenerne inalterato il valore nel tempo, anche durante il periodo della garanzia sono necessarie una manutenzione e una cura adeguate che non sono comprese nell'obbligo della garanzia. Eventuali difetti devono essere corretti subito dopo il rilevamento.

### ***Trattamento protettivo del portoncino***

Tutte le parti in legno del portoncino devono essere sempre sottoposte a trattamento protettivo. Prima dell'installazione, è necessario eseguire il trattamento integrale dei punti che successivamente non risulteranno più accessibili.

Nel caso venga utilizzato un prodotto contro il turchino, prevedere successivamente l'applicazione di un doppio strato di impregnante per legno a poro aperto. Si consiglia di ripetere l'applicazione dello strato protettivo al massimo ogni due anni.

È necessario ricordare che, in caso di utilizzo di vernici non adatte, le placche in plastica inserite potranno presentare delle differenze cromatiche rispetto ai portoncini.

Nel caso di edifici colorati e impregnati a pressione, il trattamento successivo interesserà solamente i punti e le parti in legno lasciati al naturale

Una copertura del colore uniforme nell'area interna deve essere raggiunta verniciando una volta la parte interna con una vernice a base di resine acriliche in dispersione acquosa a poro aperto.

Per assicurare una lunga durata del prodotto, eventuali punti danneggiati devono essere riparati in modo tempestivo, carteggiando leggermente e applicando nuovamente il colore.

Il vostro rivenditore di fiducia saprà consigliarvi degli impregnanti adatti.

Per garantire una lunga durata del portoncino e aumentarne la tenuta all'acqua, è inoltre possibile sigillare la giunzione vetro-legno con un'apposita pasta.

***Un'esecuzione non corretta delle operazioni indicate può determinare la comparsa di deformazioni, azzurramento e funghi sul legno di porte e telai e il conseguente decadimento della garanzia.***

### ***Pulizia***

Una pulizia e una cura regolari sono essenziali ai fini della durata e dell'efficienza di prodotti pregiati. La pulizia deve essere effettuata sul lato interno, su quello esterno e anche nella scanalatura nel telaio. Prima di iniziare la pulizia, verificare la compatibilità dei detergenti con il materiale da pulire.

### ***Deformazione del portoncino***

Il legno reagisce alle condizioni ambientali. Il rigonfiamento e il ritiro, cui può essere soggetto il legno a seconda delle condizioni atmosferiche, comportano variazioni dimensionali e lievi deformazioni.

Affinchè il portoncino continui a chiudersi correttamente, può rendersi necessario un intervento sulle cerniere, avvitandole o svitandole, a seconda delle condizioni atmosferiche.

***Finché il funzionamento viene garantito dalle possibilità di regolazione indicate, la deformazione del portoncino è considerata accettabile.***

La garanzia non copre danni derivanti dall'uso di forza.

### ***Regolazione del portoncino***

Per assicurare il corretto funzionamento del portoncino, lo stesso deve essere posizionato con precisione. Il telaio deve essere incassato in posizione perpendicolare al pavimento e ad angolo retto. Il telaio va inoltre montato in modo da avere la stessa larghezza sia superiormente che inferiormente.

Se il portoncino non si chiude o un battente non è ben bilanciato, il problema può essere corretto intervenendo sulle cerniere a vite, avvitandole e svitandole fino a 5 giri. Nel caso di portoncini a doppio battente, il battente fisso deve essere sempre assicurato verso l'alto e verso il basso per mezzo degli appositi meccanismi.

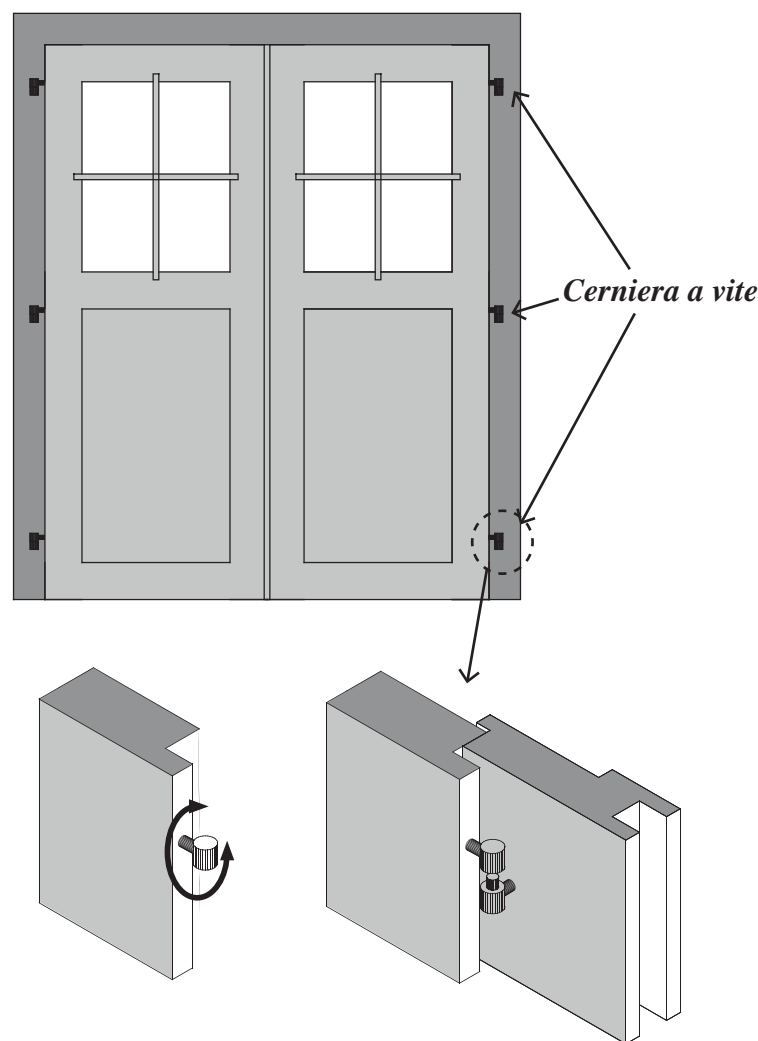

### ***Esempio di regolazione del portoncino:***

